

---

# NBAY 6120: Disruptive Technologies

## *Display Technology*

---

**Lecture #4**  
**March 13, 2018**  
**Donald P. Greenberg**

# Required Reading

---

- J.C.R. Licklider, “Man-Computer Symbiosis.” IRE Transactions on Human Factors in Electronics. March 1960. [IRE Transactions](#).



Georges Seurat, A Sunday on La Grande Jatte. 1884-1886

# A Pixel Consists of Approximately 2 2/3 Triads

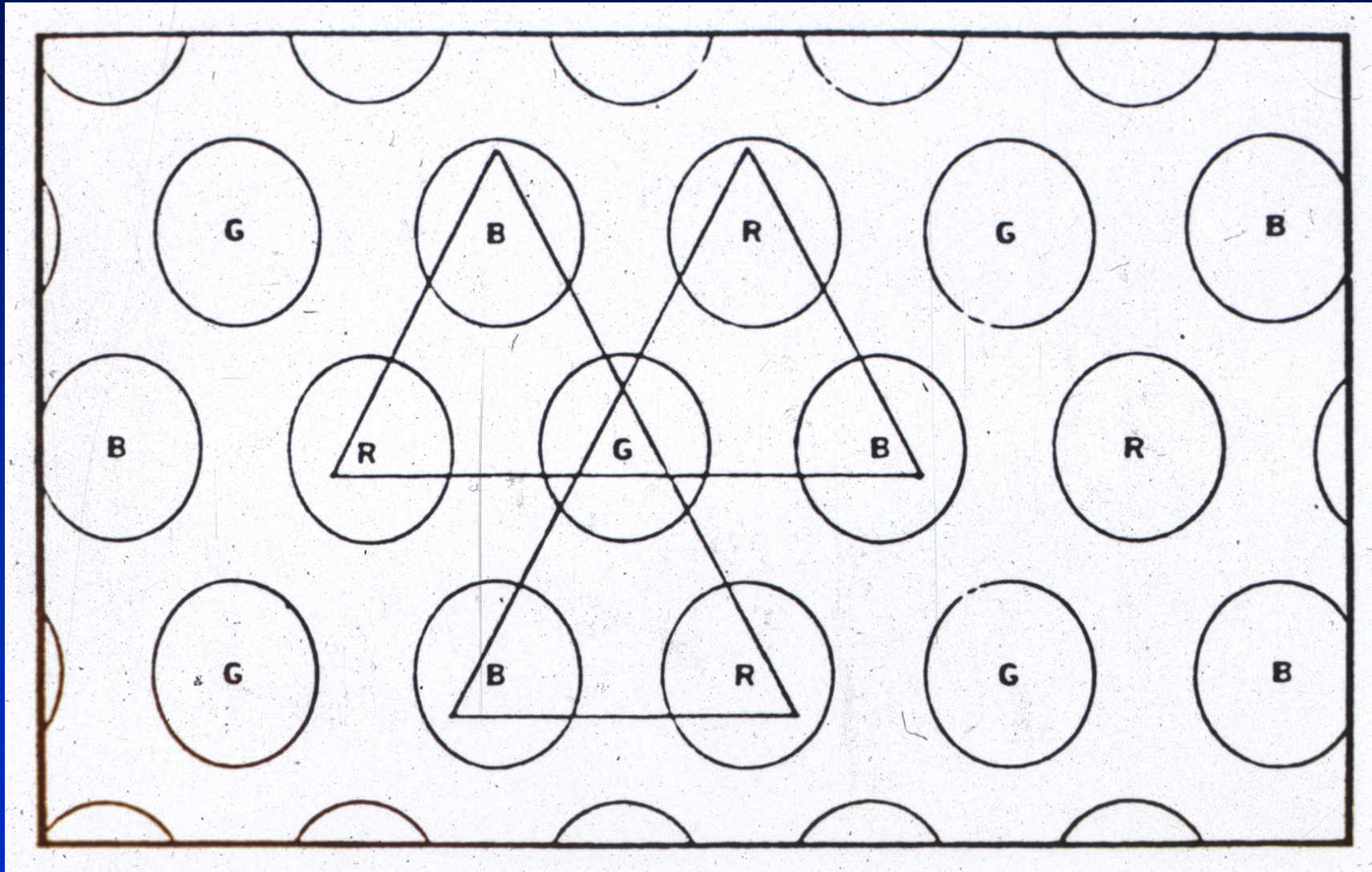

# A Pixel Consists of Approximately $2 \frac{2}{3}$ Triads

---

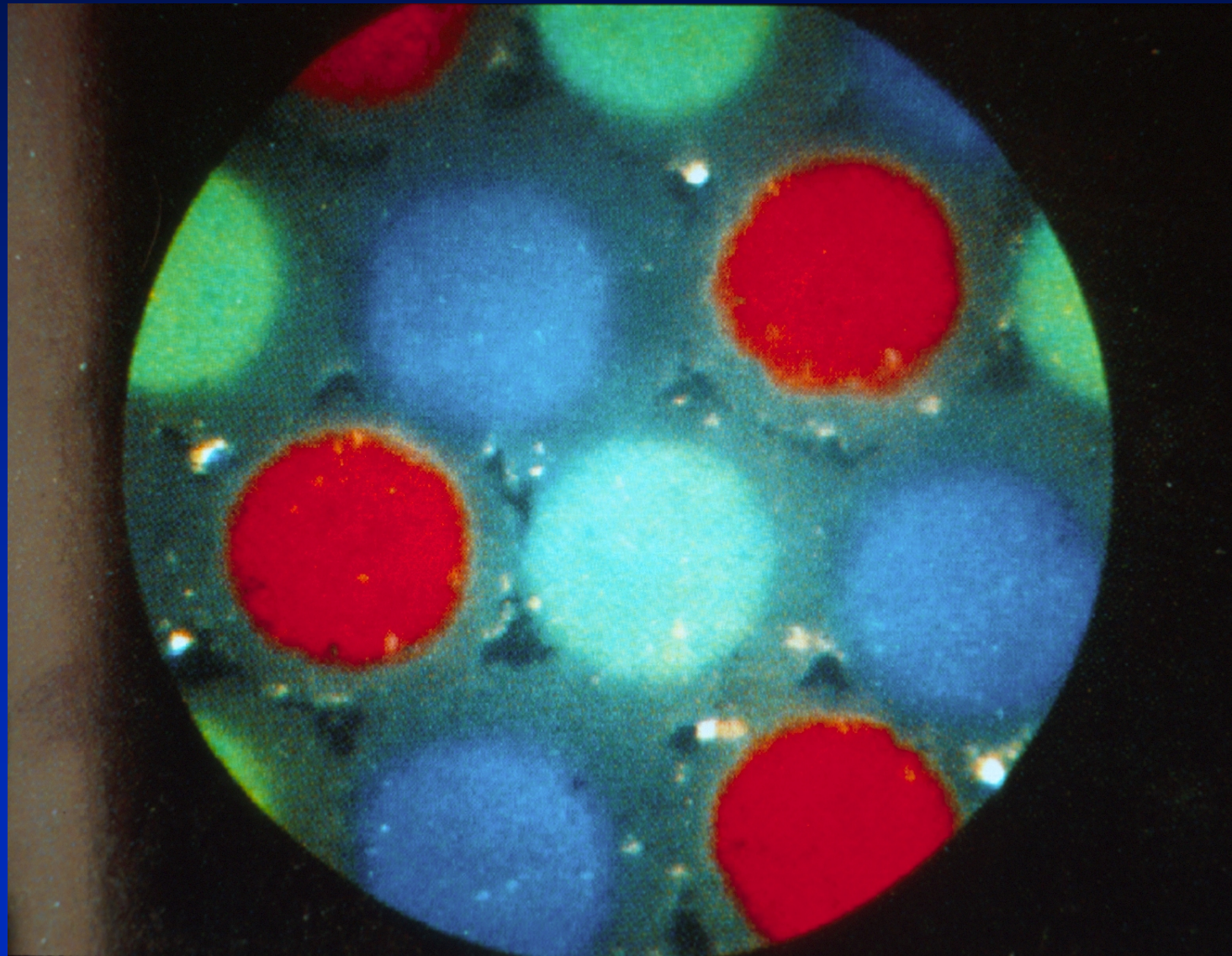

# Update Rate

---

- The update rate is the number of changed images which are displayed per second.
- For the average human observer if changed images are shown at greater than 12 frames per second one can perceive motion .

# Flicker Fusion Frequency

---

- The flicker fusion frequency of the average human observer is approximately 60 cycles per second.
- If the refresh rate is greater than this threshold, the observer sees a constant intensity.

# Phosphor Decay Behavior

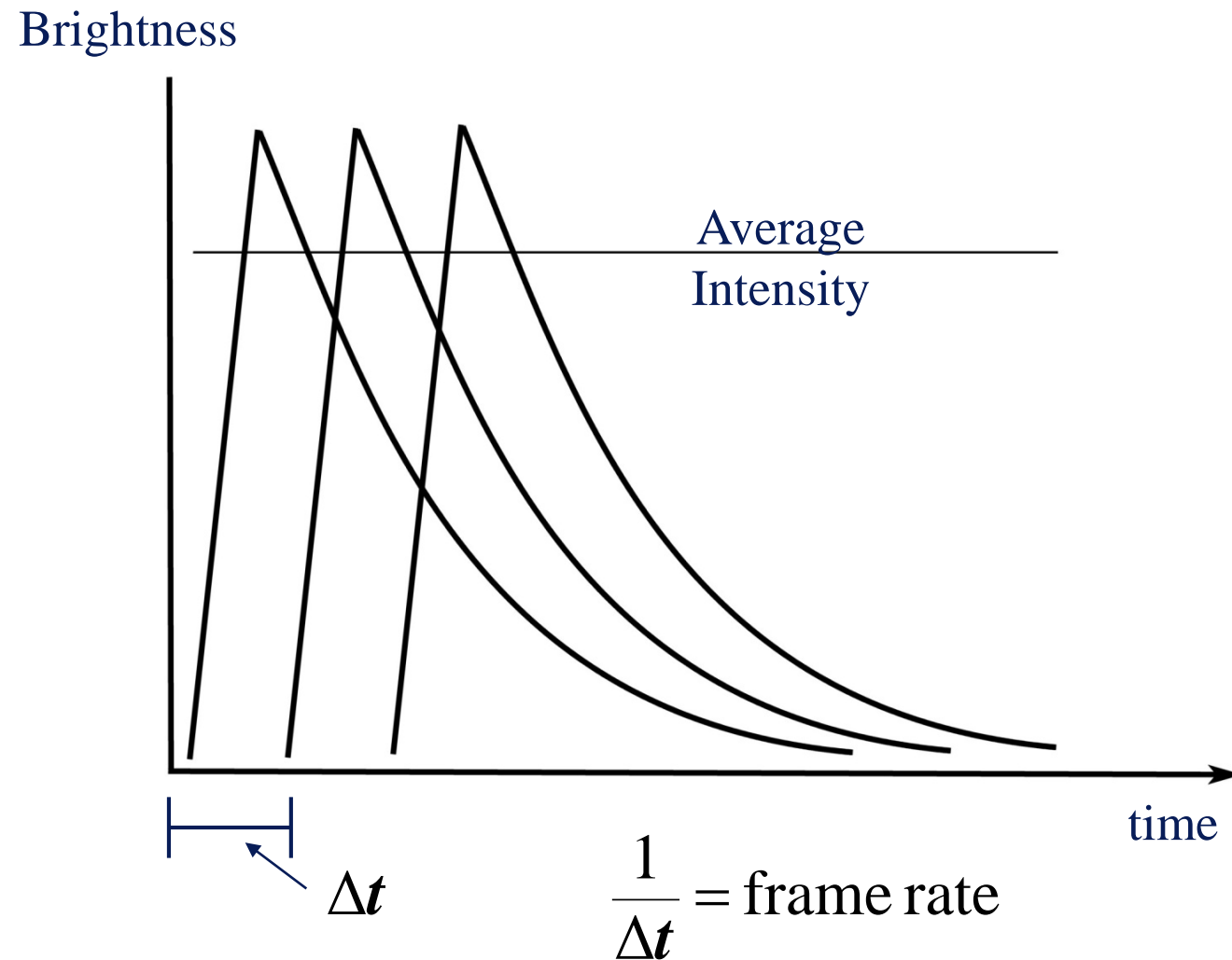



# Temporal Properties of NTSC

## REFRESH

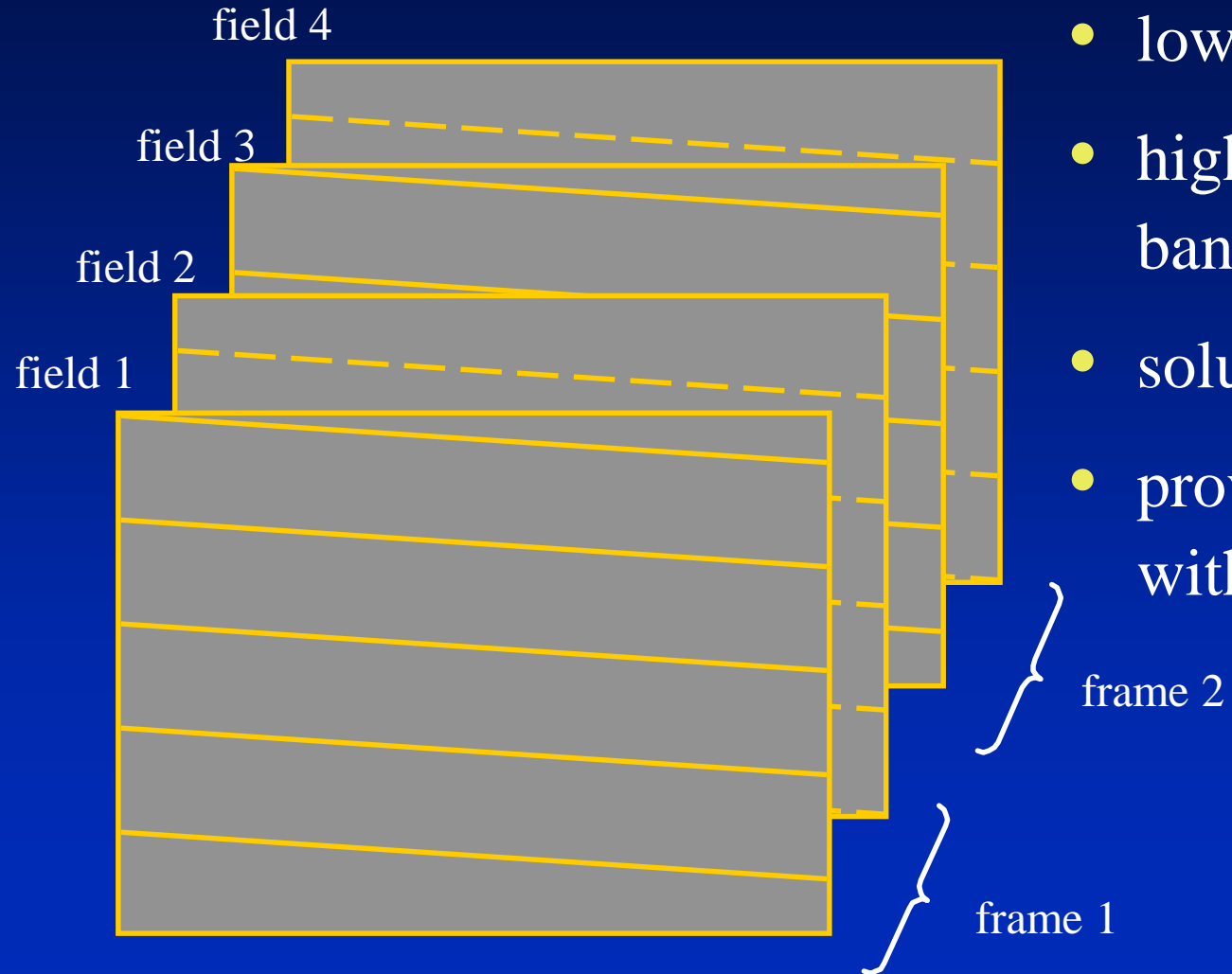

- low refresh rate -> flicker
- high refresh rate -> too much bandwidth
- solution: interlacing
- provides 60 Hz refresh rate with only 30 Hz update rate

# Update Rate vs. Refresh Rate

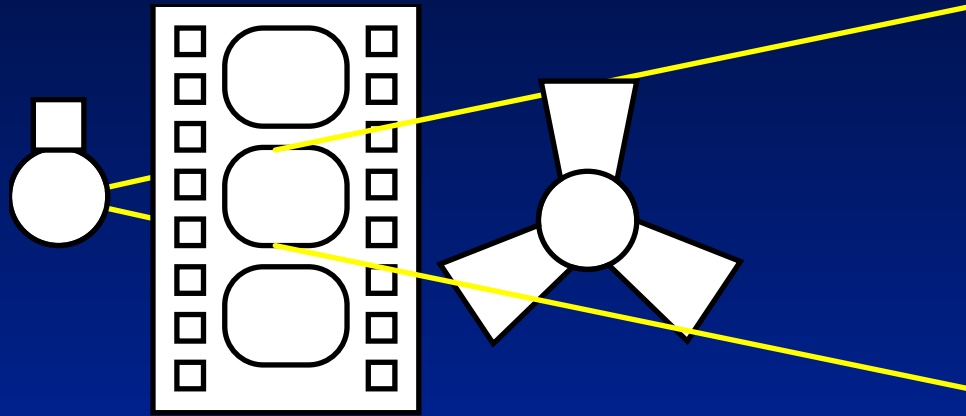

Film: 24fps update rate, 3 blade shutter, 72Hz refresh rate

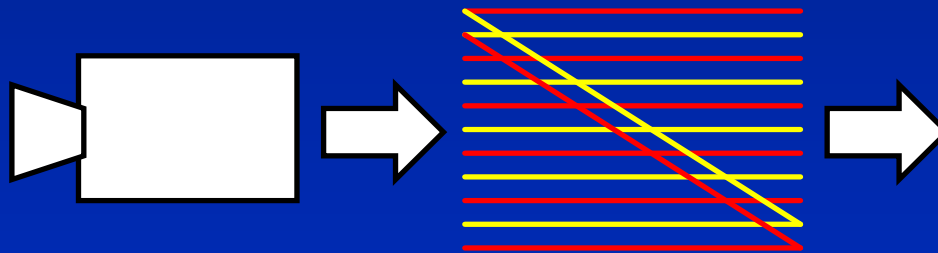

Video: 30fps update rate, 2:1 interlacing, 60 Hz refresh rate

- interlacing: matches flicker limits of vision, minimizes bandwidth

# Mapping the Frequency Spectrum

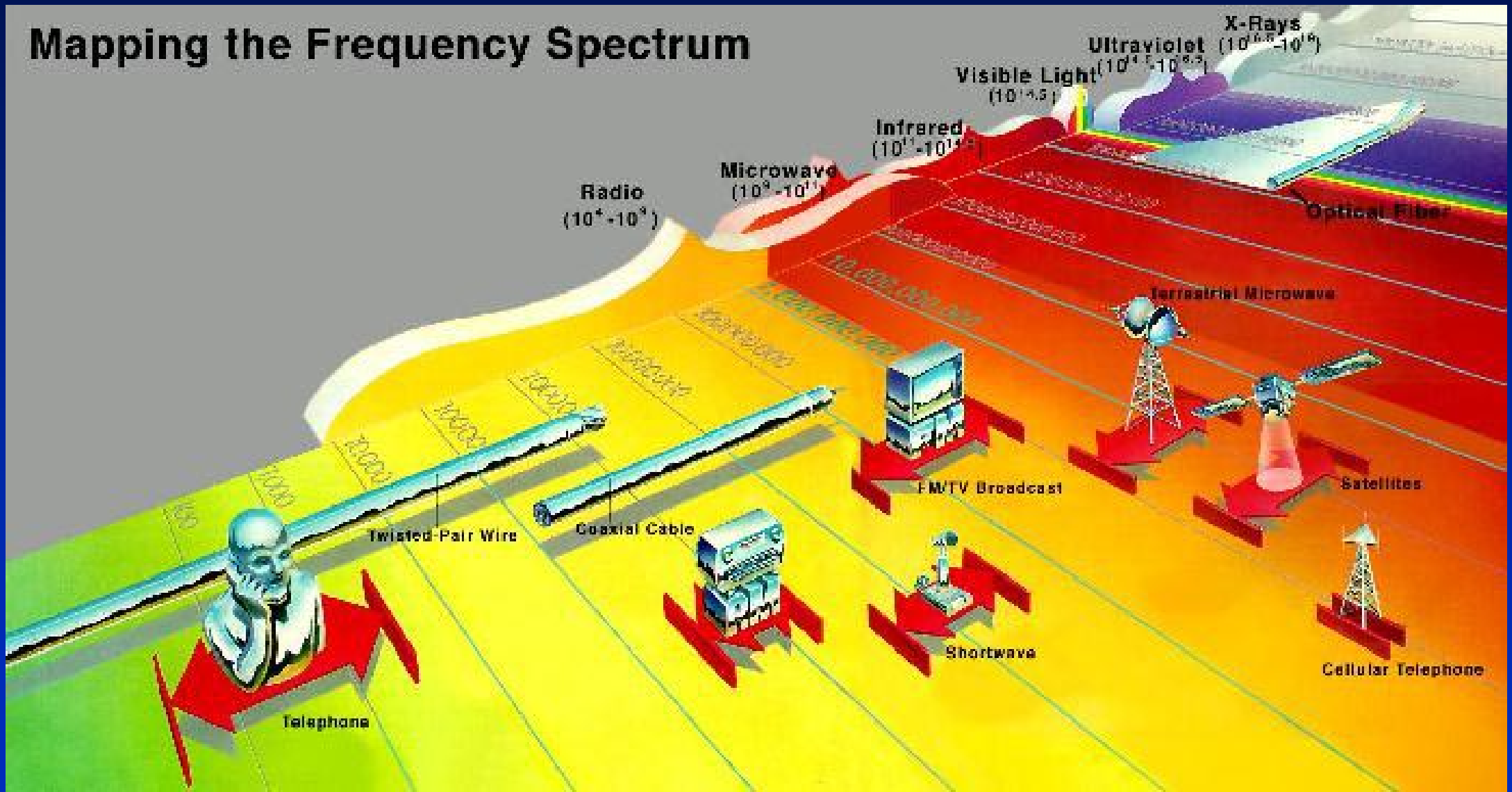

# Important Properties of Liquid Crystals

---

- Crystals are transparent
- Can alter the orientation of polarized light passing through them
- Polarization properties can be changed by applying electrical field
- Switching can be done fast

# Polarization of Liquid Crystal

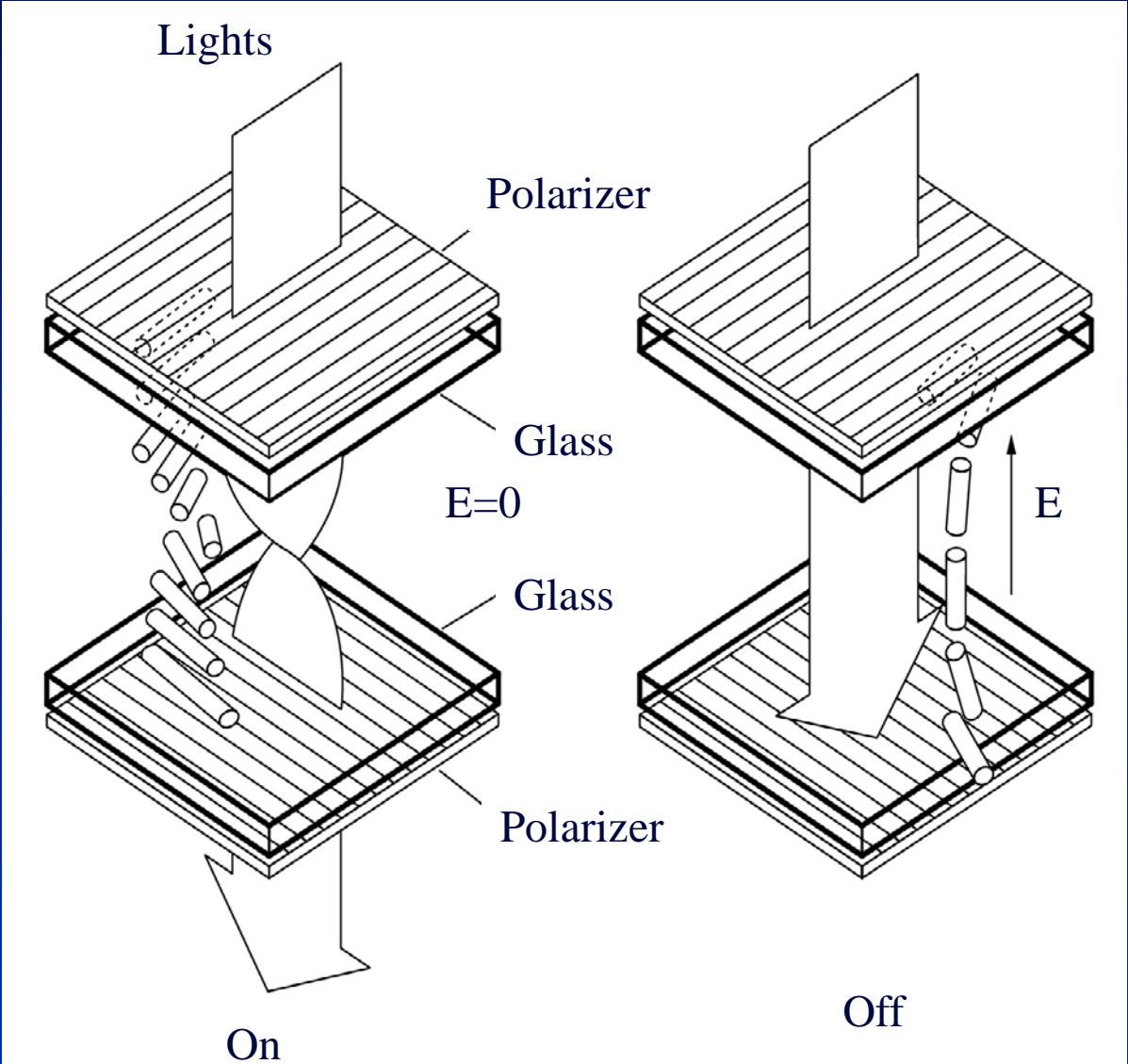

# Liquid Crystal Color Display

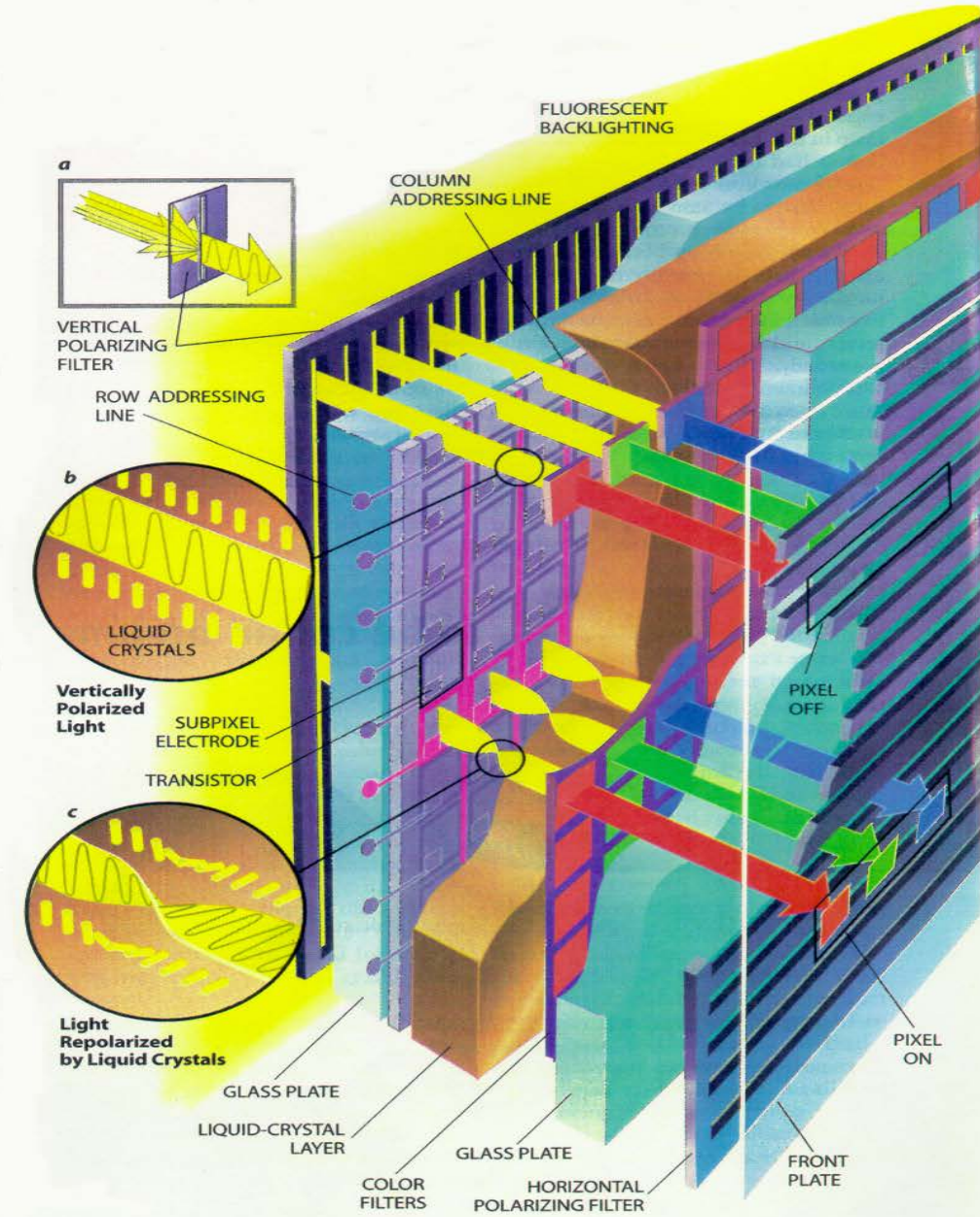

# LCD Advantages & Disadvantages

---

- Can have high resolution. (Corning & Samsung)
- Requires very flat glass panels which are now being produced relatively cheaply.

# Plasma Display Technology

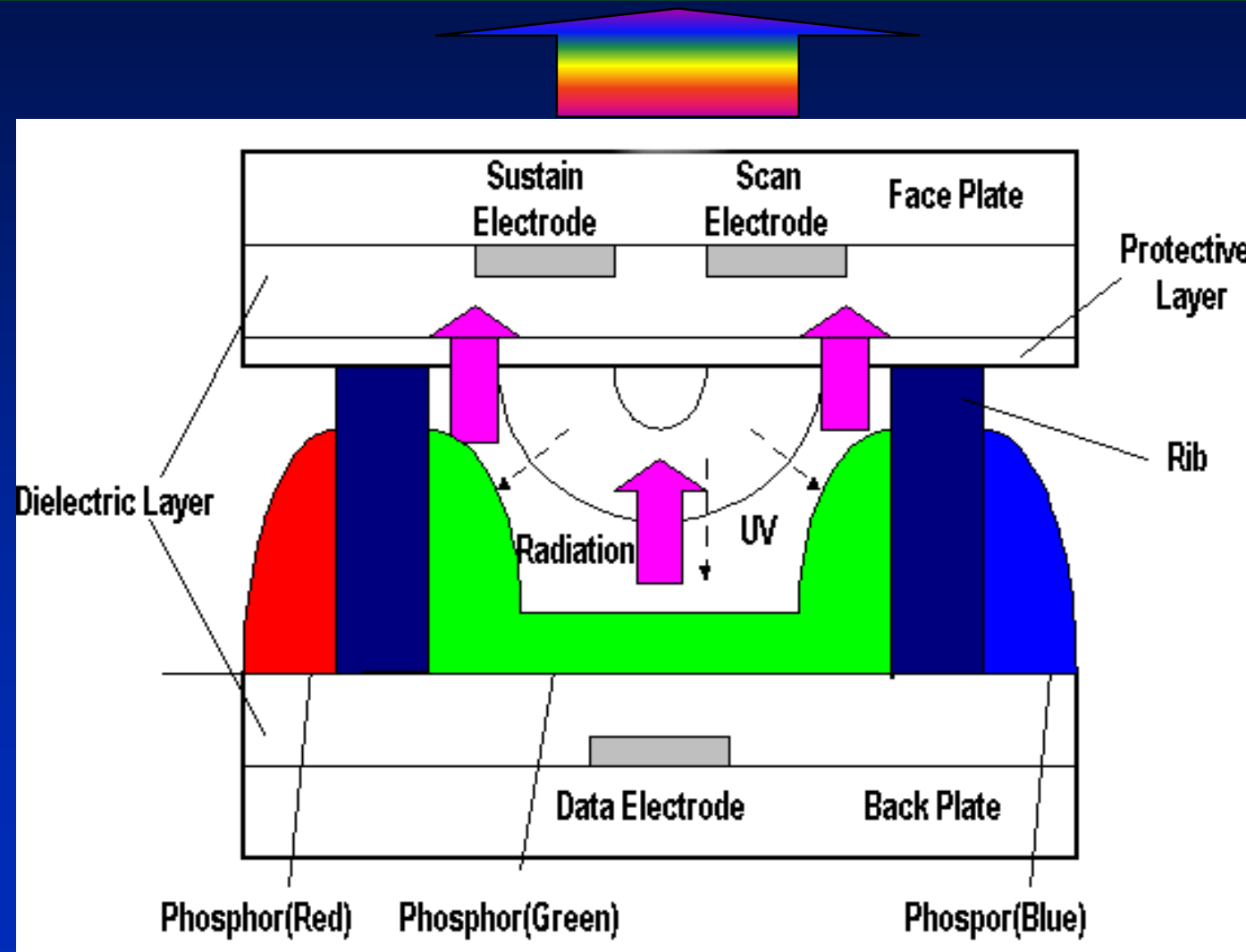



# Plasma Display: Advantages & Disadvantages

---

- The advantage is that they can have high brightness (at the expense of watts). Thus can be used in brightly lit areas.
- The difficulty with plasma displays is that the cell size (pixel) is large relative to a liquid crystal. Thus for a given resolution, the screens must be large.

# Digital Micromirror Devices (DMD)

---

- Pioneered by Texas Instruments. The research on these micromechanical (MEMs) devices started in 1977.
- The first digital light valve projection systems (DLPs) had mirrors measuring 17 microns per side. At 1280 x 1028 resolution (HDTV) this resulted in a rather large chip in 1996.

# DMD Structure

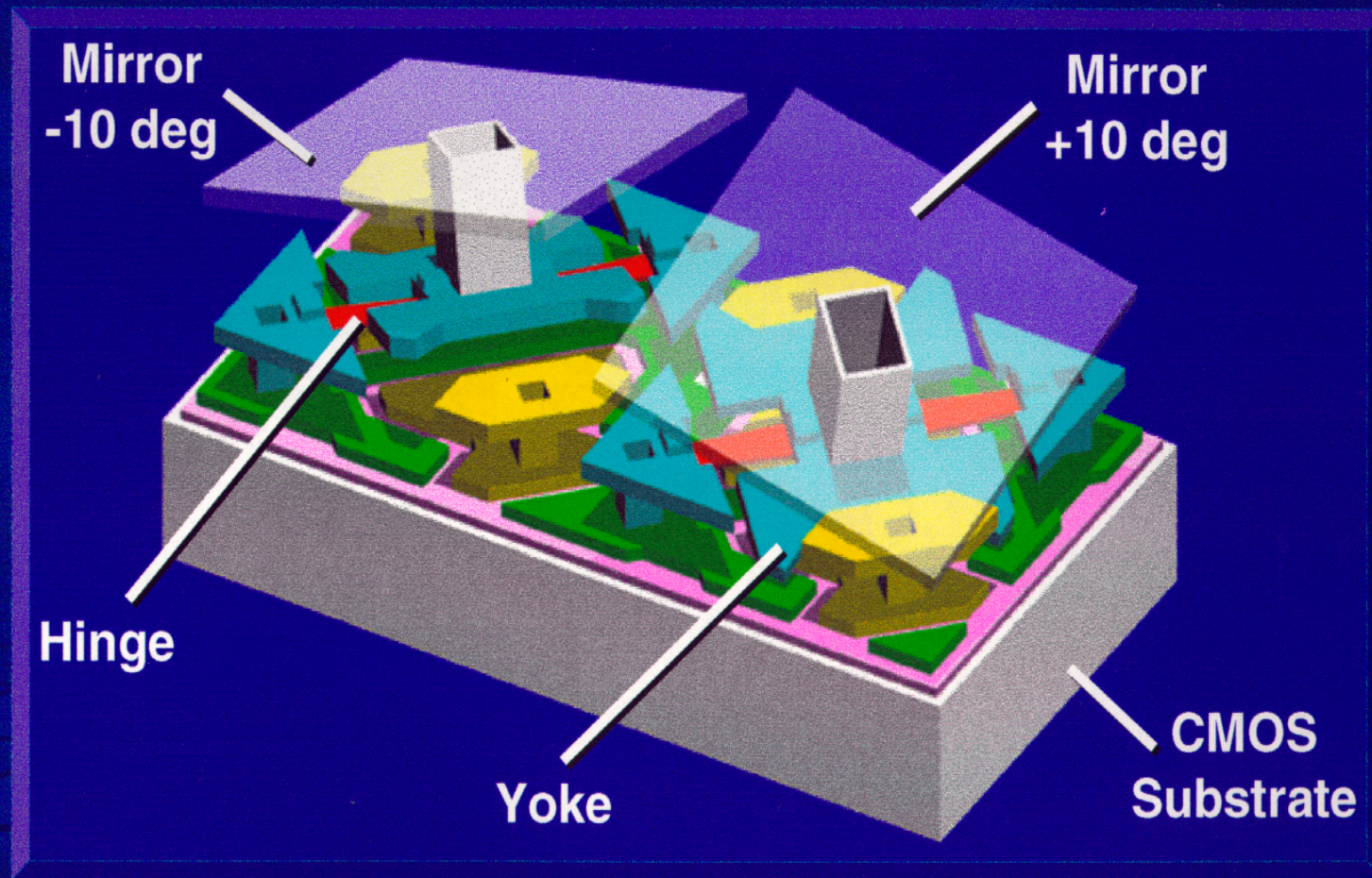

**Digital Micromirror Device (DMD™)**  
**A True Microelectromechanical System**

# DMD™ Devices

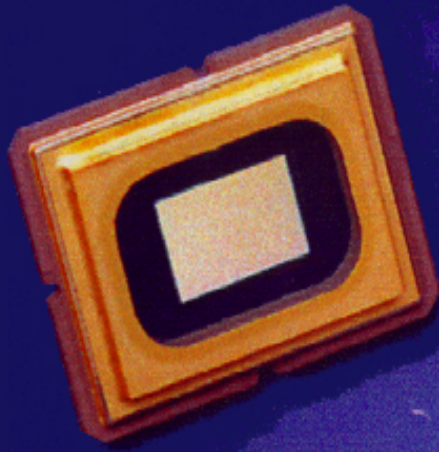

**SVGA**  
(800 x 600)

**XGA**  
(1024 x 768)

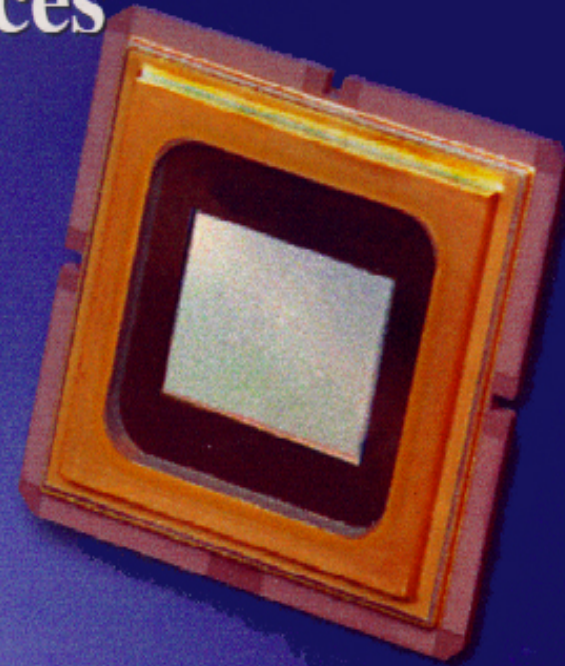
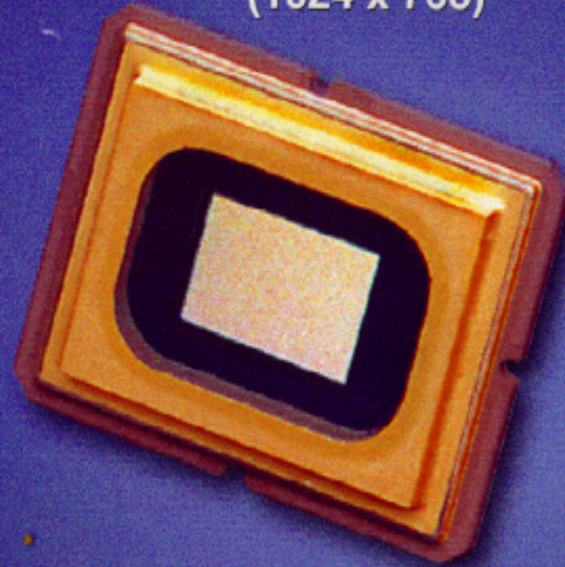

**SXGA**  
(1280 x 1024)





# DMD™ Switching Example (1 On)

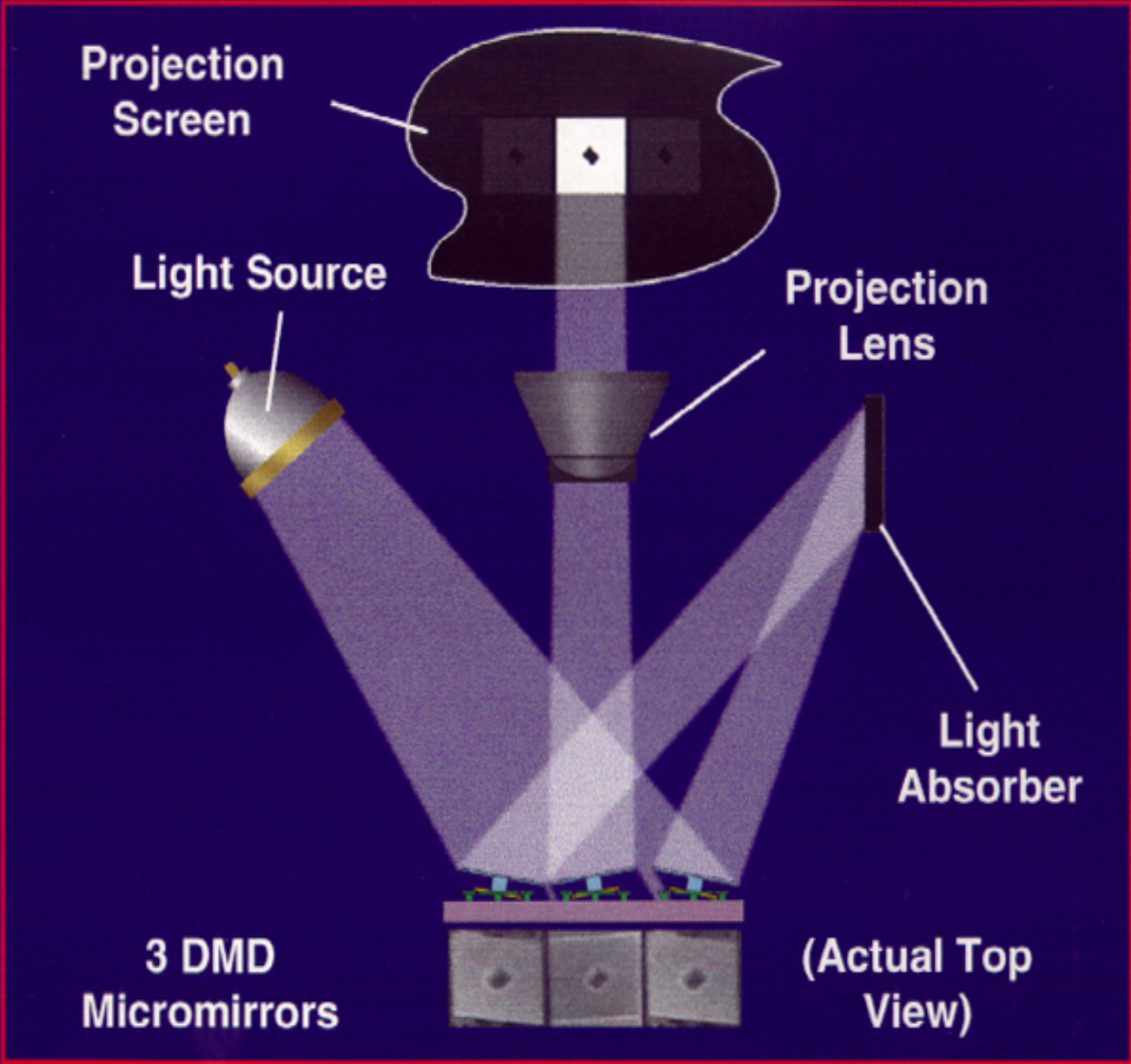

# DMD™ Grayscale Projection

## Pulsewidth Modulation

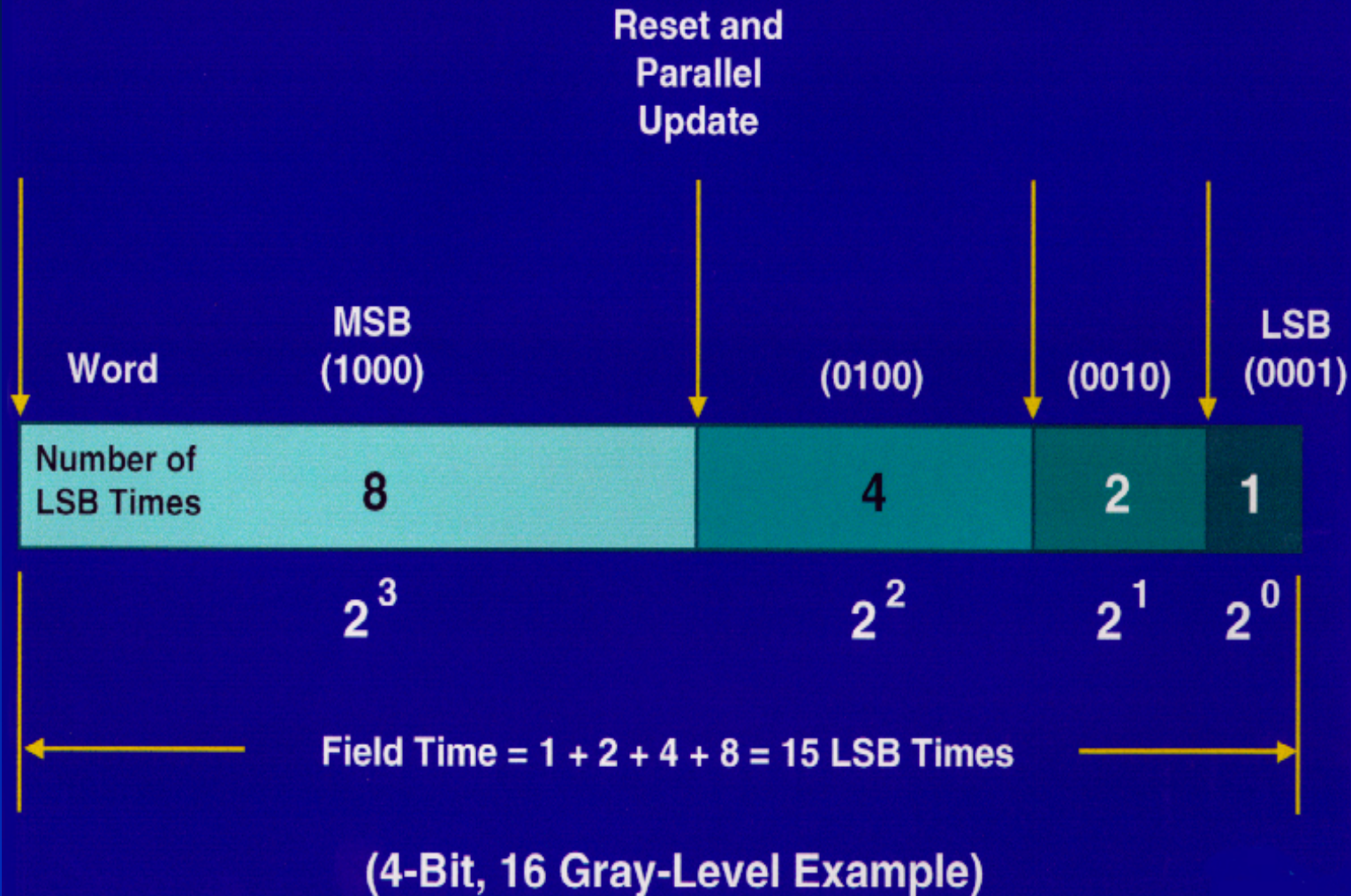

# How Grayscale is Created

## DMD™ Binary Pulsewidth Modulation

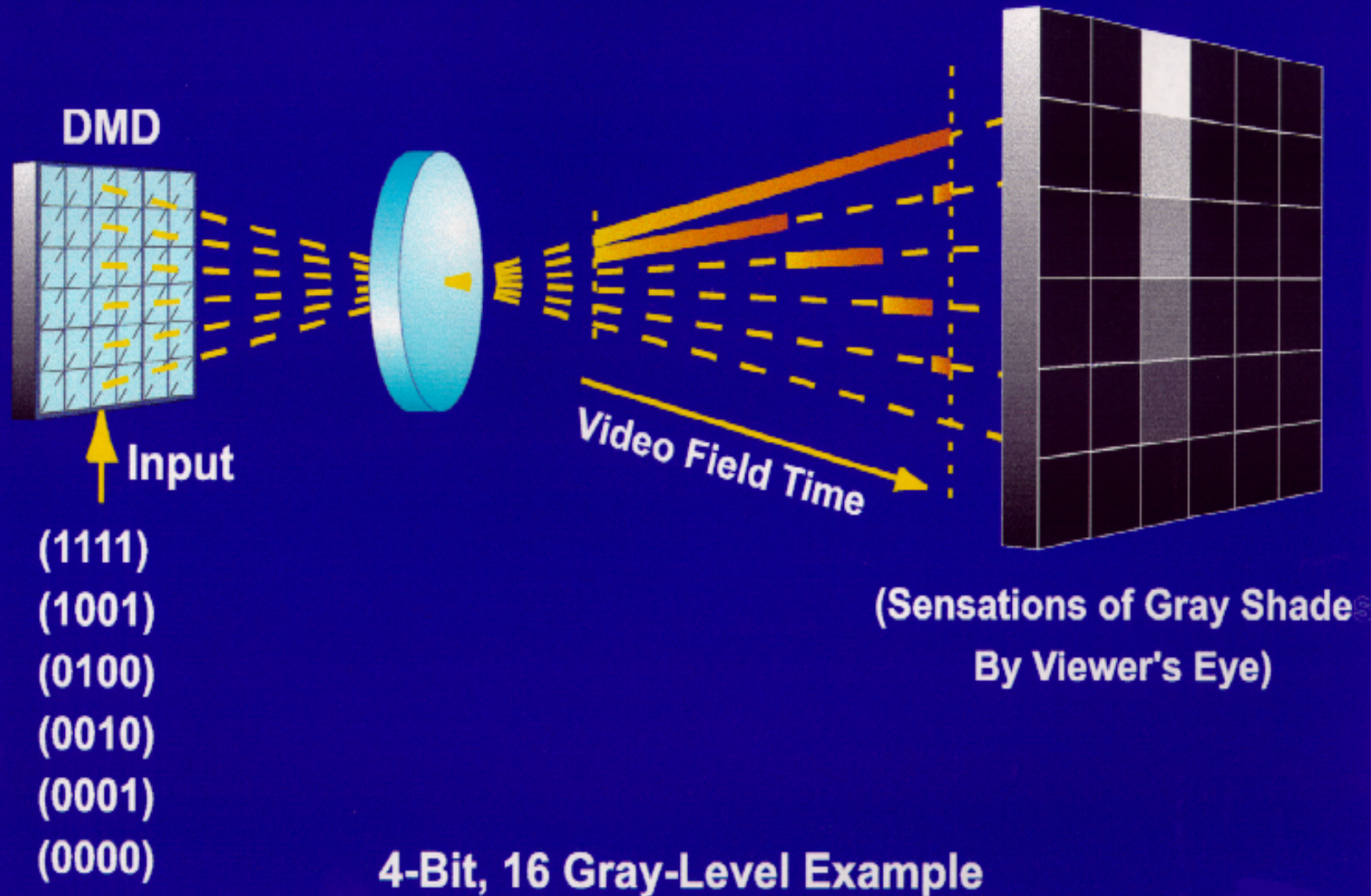



# Example: Lenna Original

---





1000

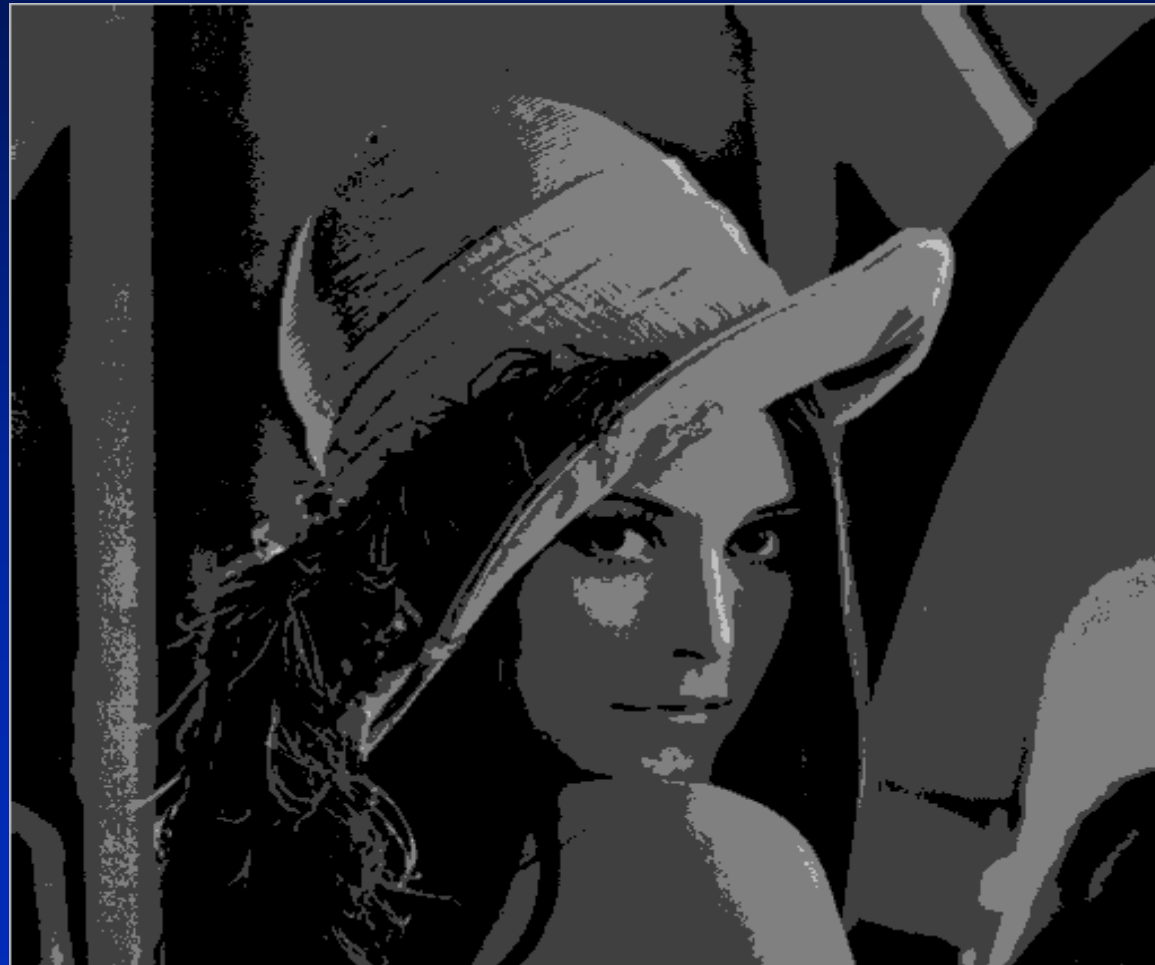





11111111

# 3-Chip DLP Optical System

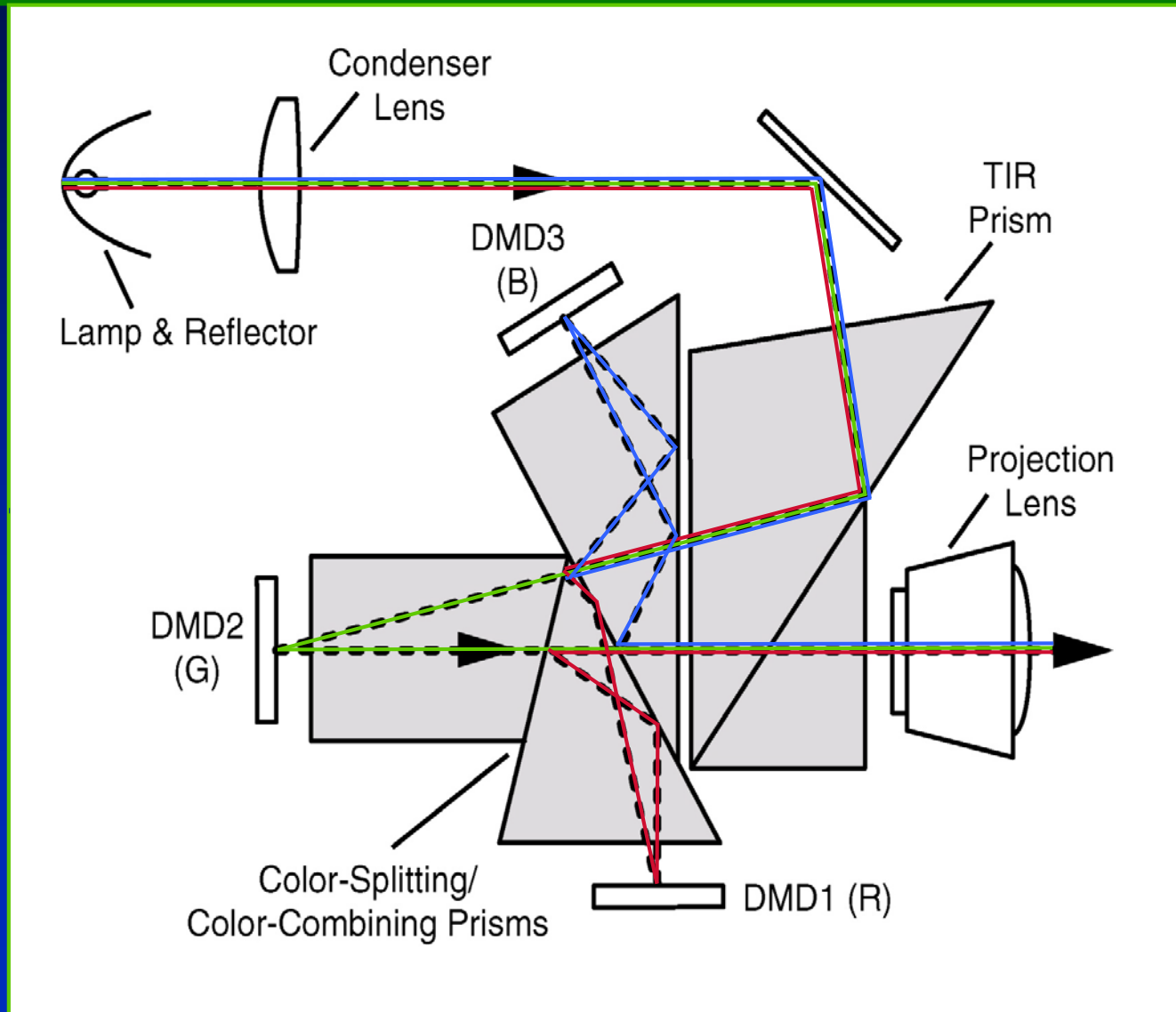

# Digital Micromirror Devices (DMD)

---

- Pioneered by Texas Instruments. The research on these micromechanical (MEMs) devices started in 1977.
- The first digital light valve projection systems (DLPs) had mirrors measuring 17 microns per side. At 1280 x 1028 resolution (HDTV) this resulted in a rather large chip in 1996.
- Today this technology is used in almost all digital theaters and some home televisions.
- Most theaters now use DLP with 4K resolution (4096 x 2160)

# Cost of HDTV Displays

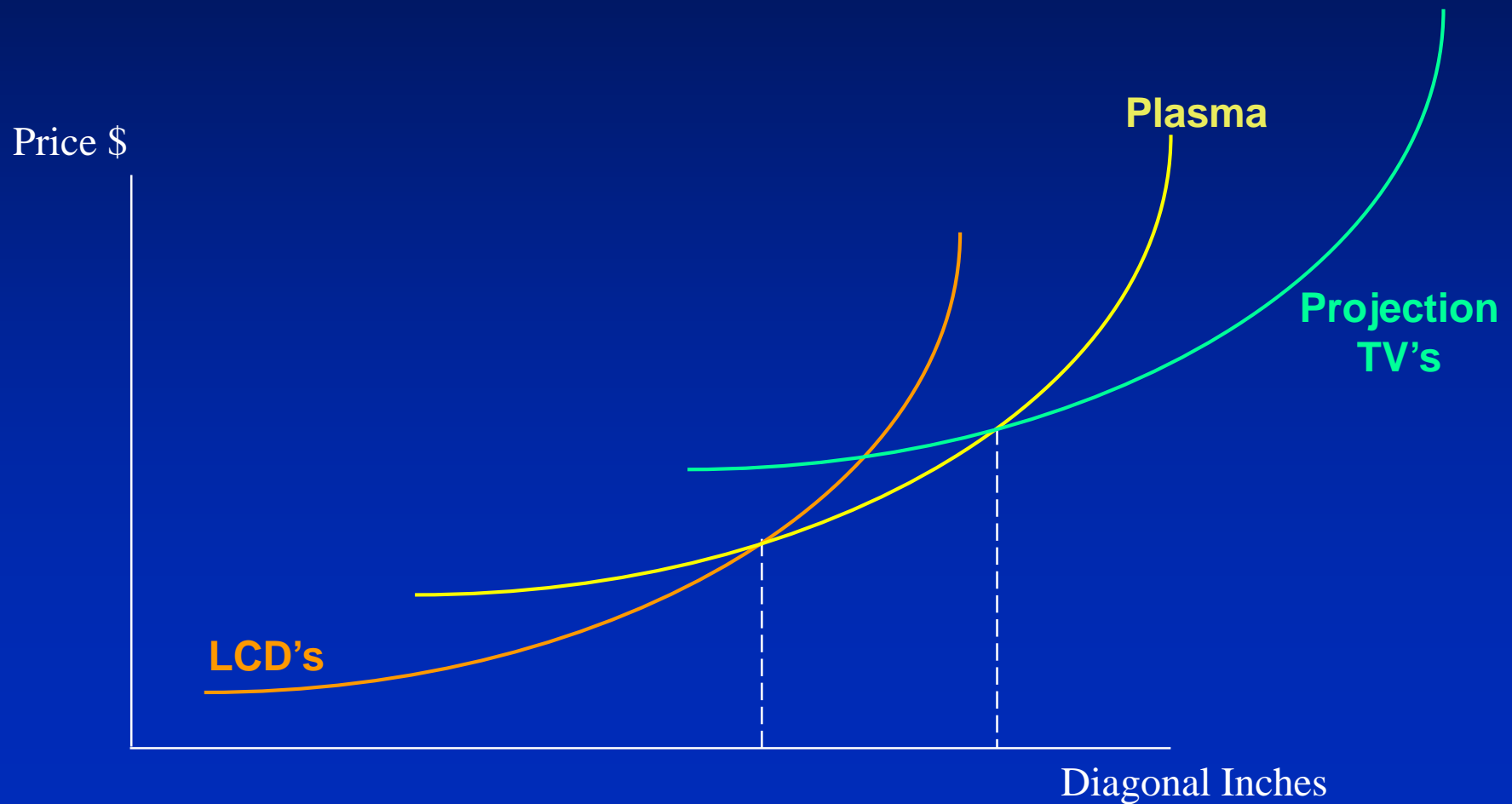



# Cost of HDTV Displays

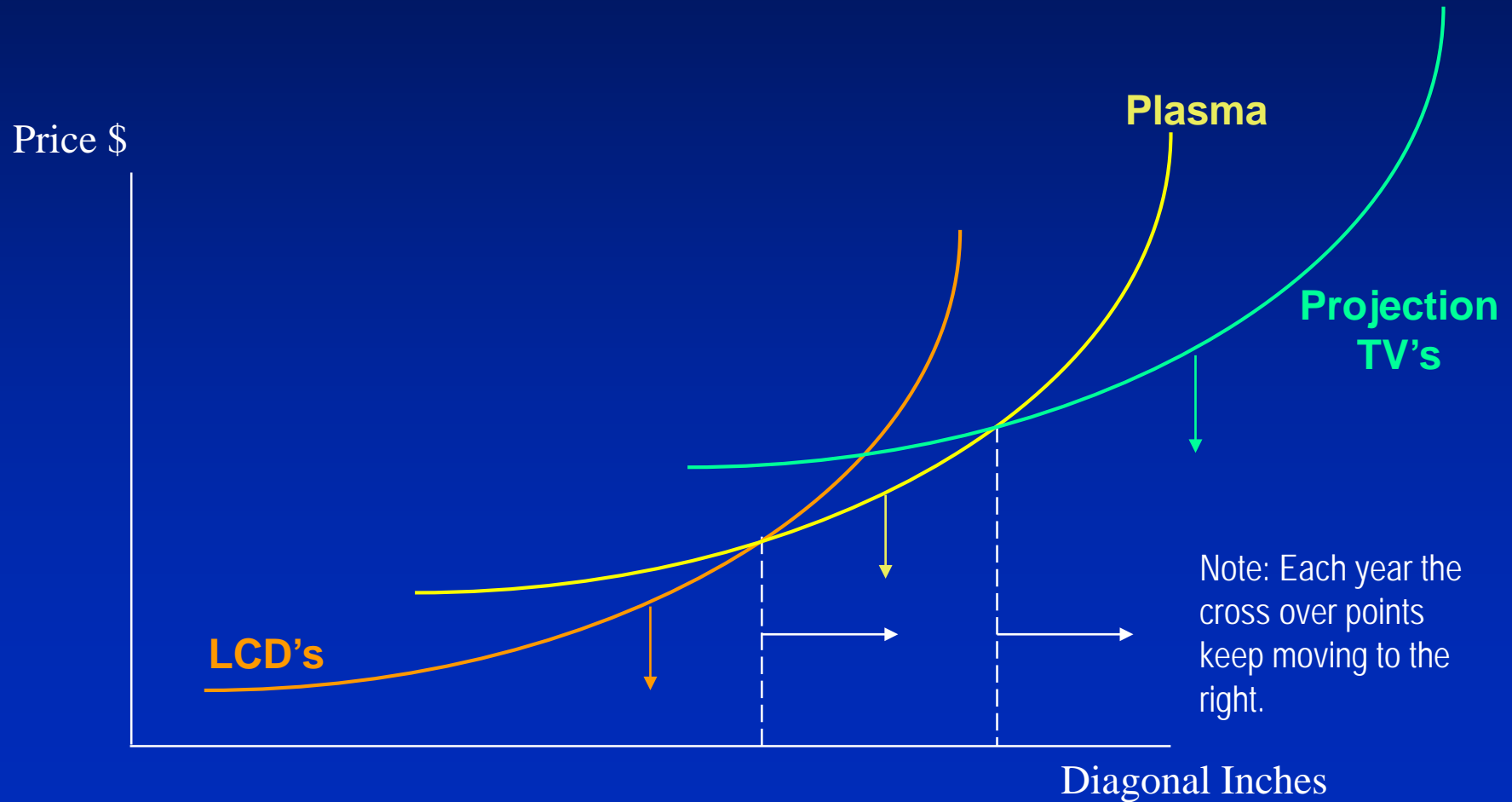

# Modifications to Existing Technology

---

- The quest for size
- The quest for brightness
- The quest for reduced energy
- The quest for mobility
- The quest for resolution

# Cornell Panoramic Projection System



# NASA Ames Control Room



# Stonybrook's Reality Deck

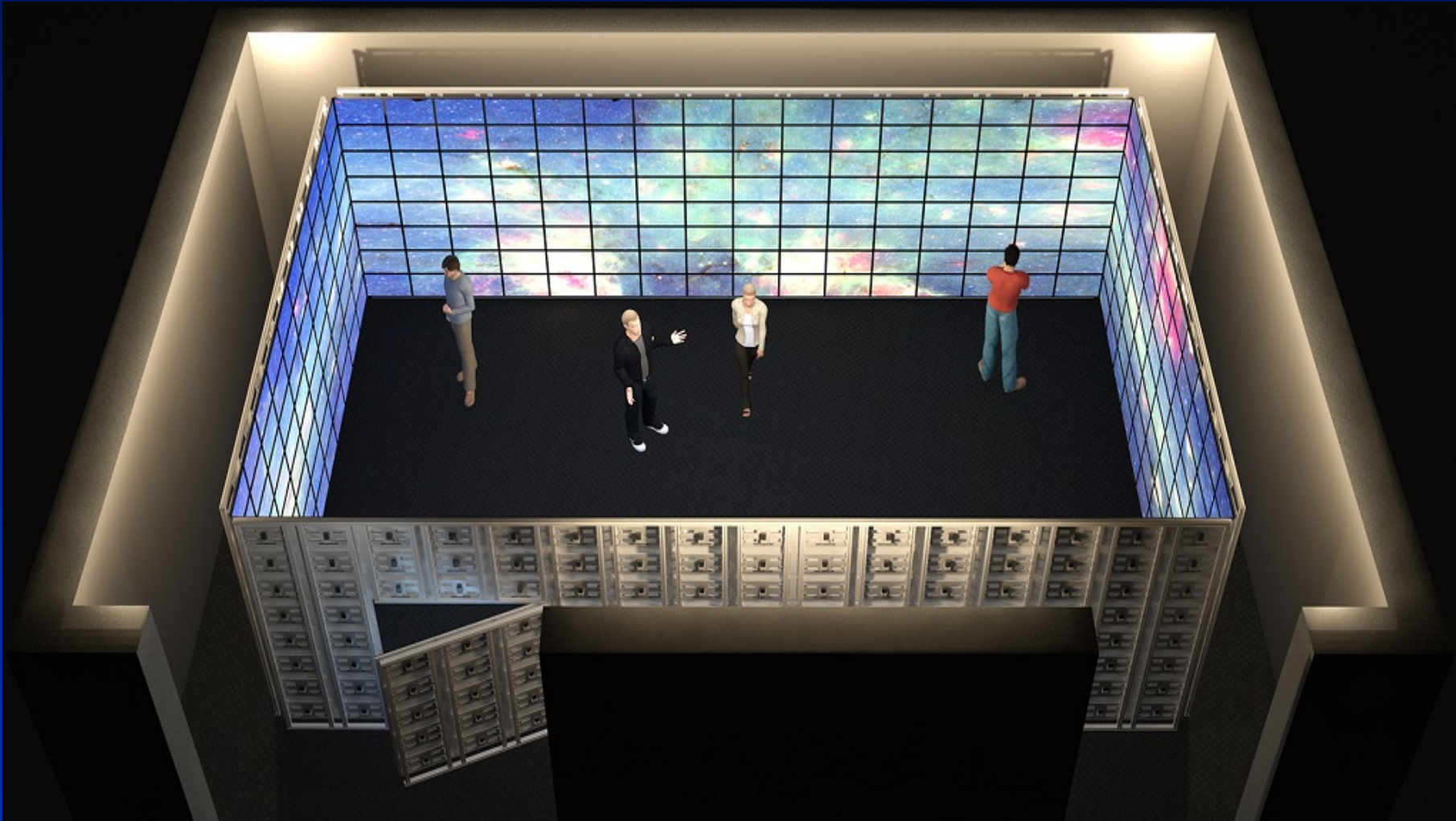

# Samsung 110-inch 4K UHD TV 2014



# Christie CP4230 Digital Cinema Projector

2018

- 4K DLP
- Screen size up to 105ft (32m)
- 4096 x 2160 resolution
- 2100:1 contrast



# Visual Adaptation

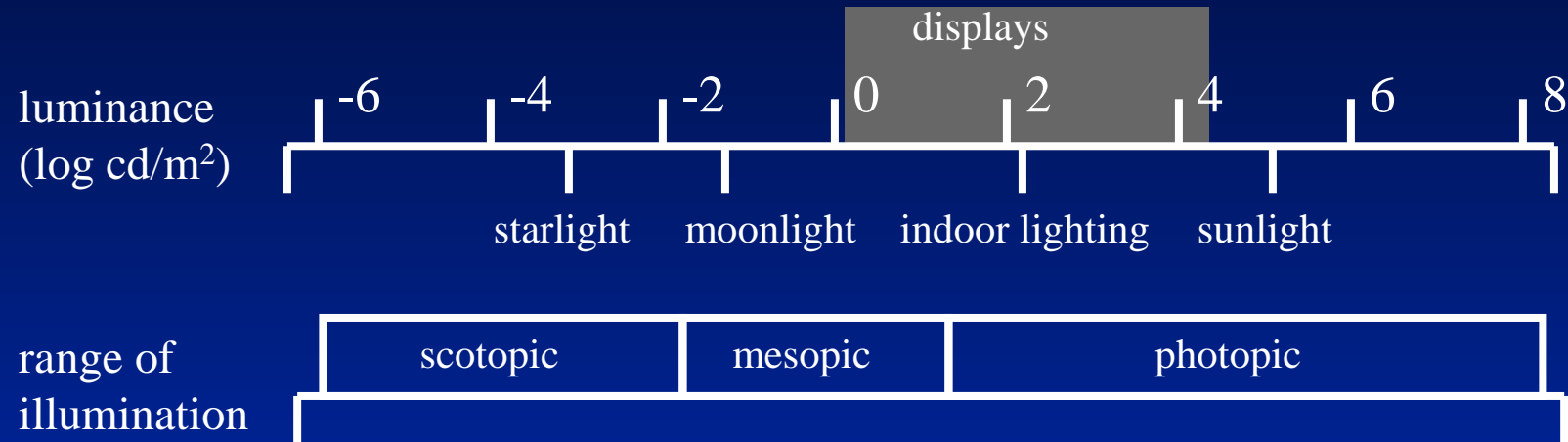

- poor contrast
- no color
- low acuity

- good contrast
- good color
- high acuity



# Sunnybrook Display Technology



High resolution  
colour LCD



High Dynamic Range  
Display

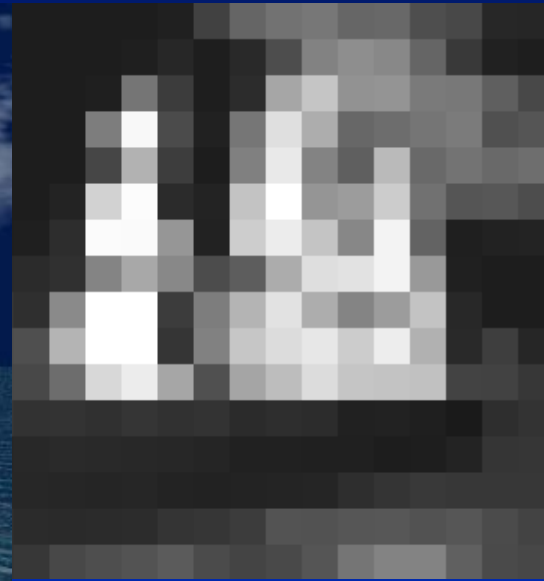

Low resolution  
Individually Modulated  
LED array

# The XO and One Laptop Per Child

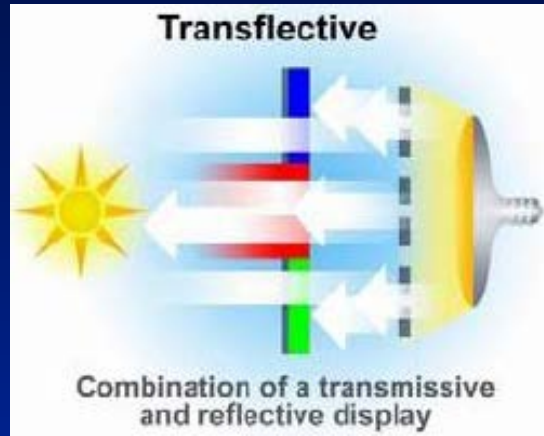

The custom XO display contains a reflective layer between its backlight and the specially formatted LCD layer, allowing it to turn high ambient lighting conditions to its advantage.

The display is not only inexpensive (\$30/unit), but is also much easier on the eyes.



# OLPC XO-4 Touch

August 2013

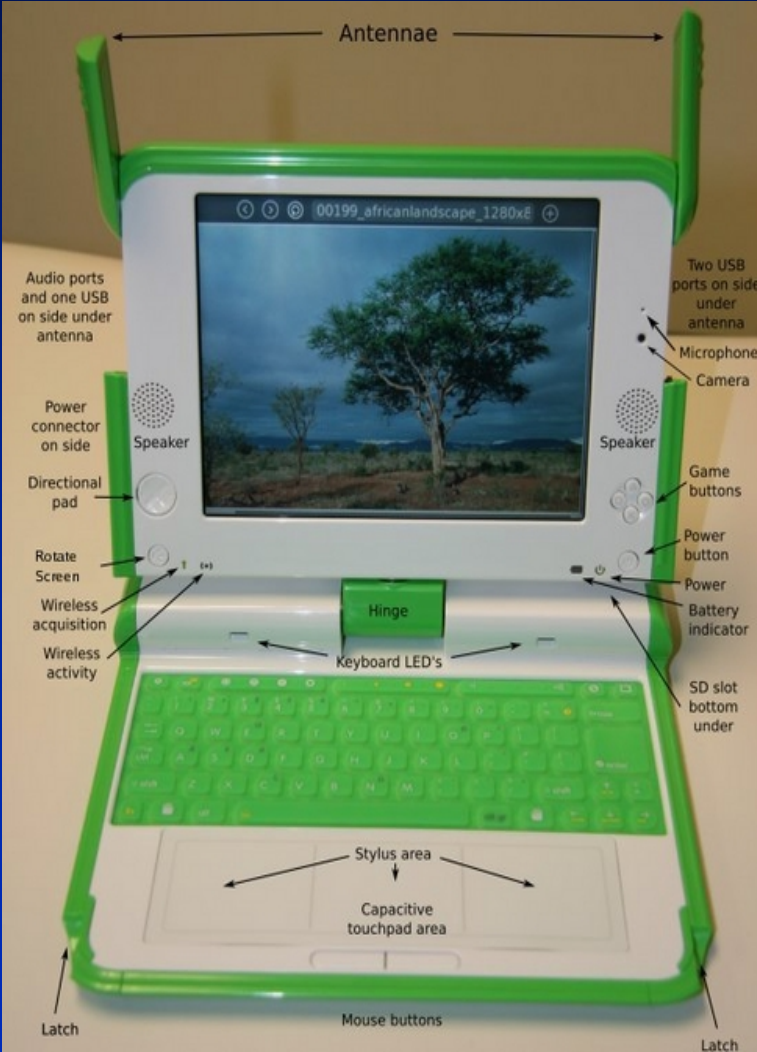

# Images Through Screen Doors



# Pixel Qi



# Pixel Qi



# Organic LEDs (OLEDs)

SOFT LIGHT: Junji Kido of Yamagata University shows off his bright and smooth prototype OLED system.



SOFT LIGHT: Junji Kido of Yamagata University shows off his bright and smooth prototype OLED system.

# Organic LEDs (OLEDs)

---

- Composed of a thin film of organic compounds and conductive layers sandwiched between two electrodes
- When the charges recombine in the organic layer, energy is released in the form of photons
- Can be made with fluorescent-based or phosphorescent material



# Organic LEDs (OLEDs) Advantages

---

- In theory, the energy of this conversion could reach 100%
- Thickness can be measured in nanometers (extremely thin and lightweight) excluding the substrate
- Can be manufactured in sheet form
- Can be put on a variety of substrates including flexible plastic
- Material is environmentally friendly (no harmful elements)

# Potential Uses

---

- Could be applied as wallpaper for illumination purposes
- Very bright and can replace light bulbs – already 4x more efficient than light bulbs in terms of lumens/watt
- With ability to produce red, green, and blue (new), can be used for displays

# OLED Explanation

- A. A voltage is applied across the OLED such that the anode is positive with respect to the cathode. Electrons flow from cathode to anode.
- B. Thus the cathode gives electrons to the emissive layer and the anode withdraws electrons from the conductive layer (causing electron holes).

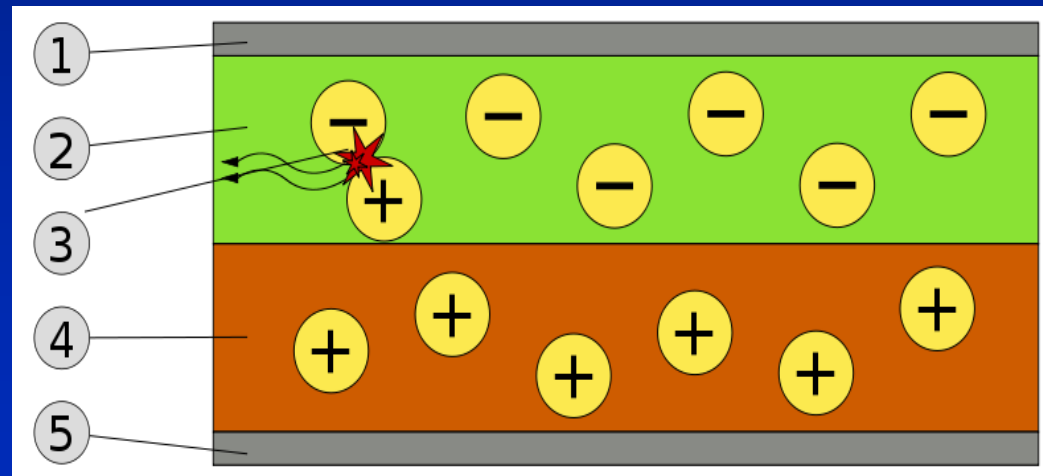

# OLED Explanation

- C. Electrostatic forces bring the electrons and holes together and they recombine.
- D. In organic semiconductors, holes are more mobile than electrons. This happens closer to the emissive layer.
- E. The recombination causes an emission of radiation whose frequency is in the visible region.

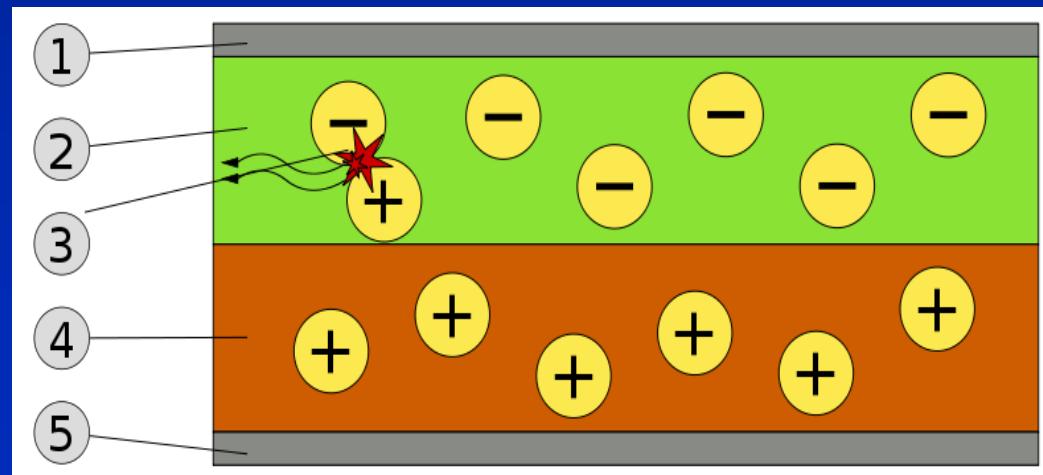

# Sony 27-inch OLED Panel

2007



# Samsung Curved OLED TV

---



# LG press-on 'wallpaper' TV under 1mm thick



# How E-Paper Works

## GYRICON BEADS

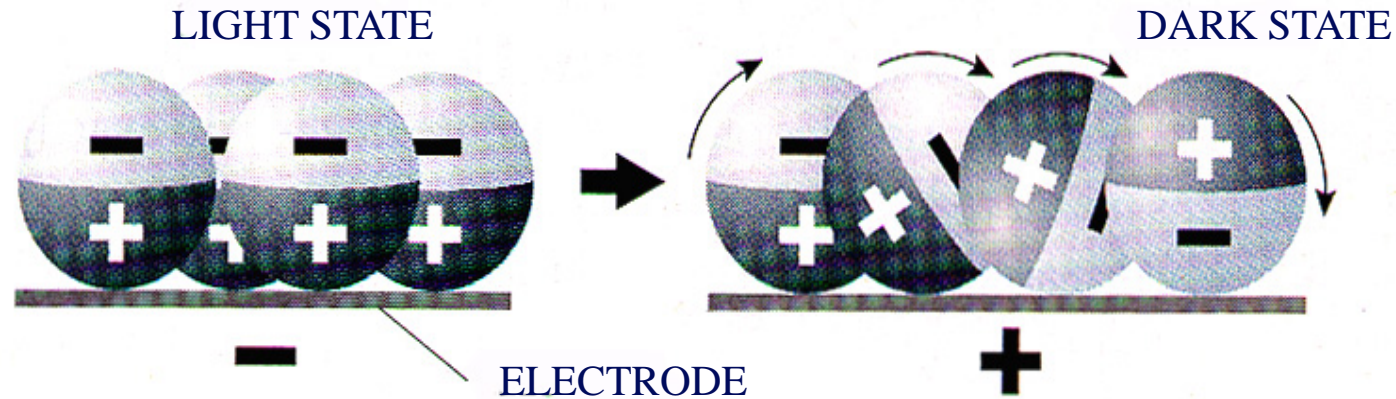

## E INK MICROCAPSULES

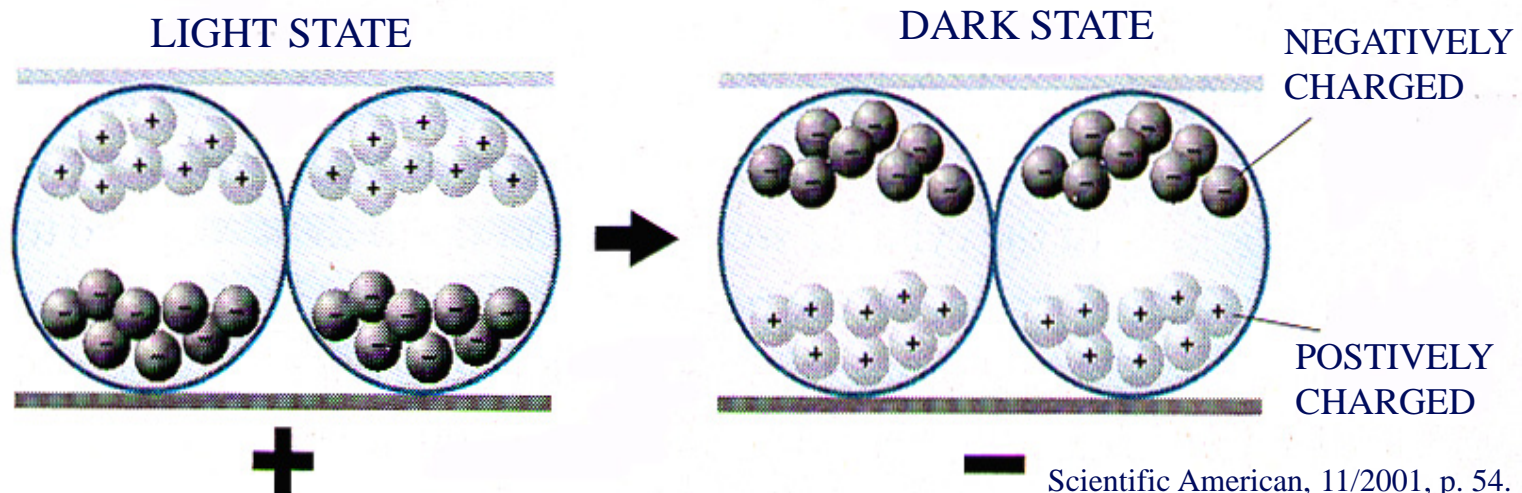



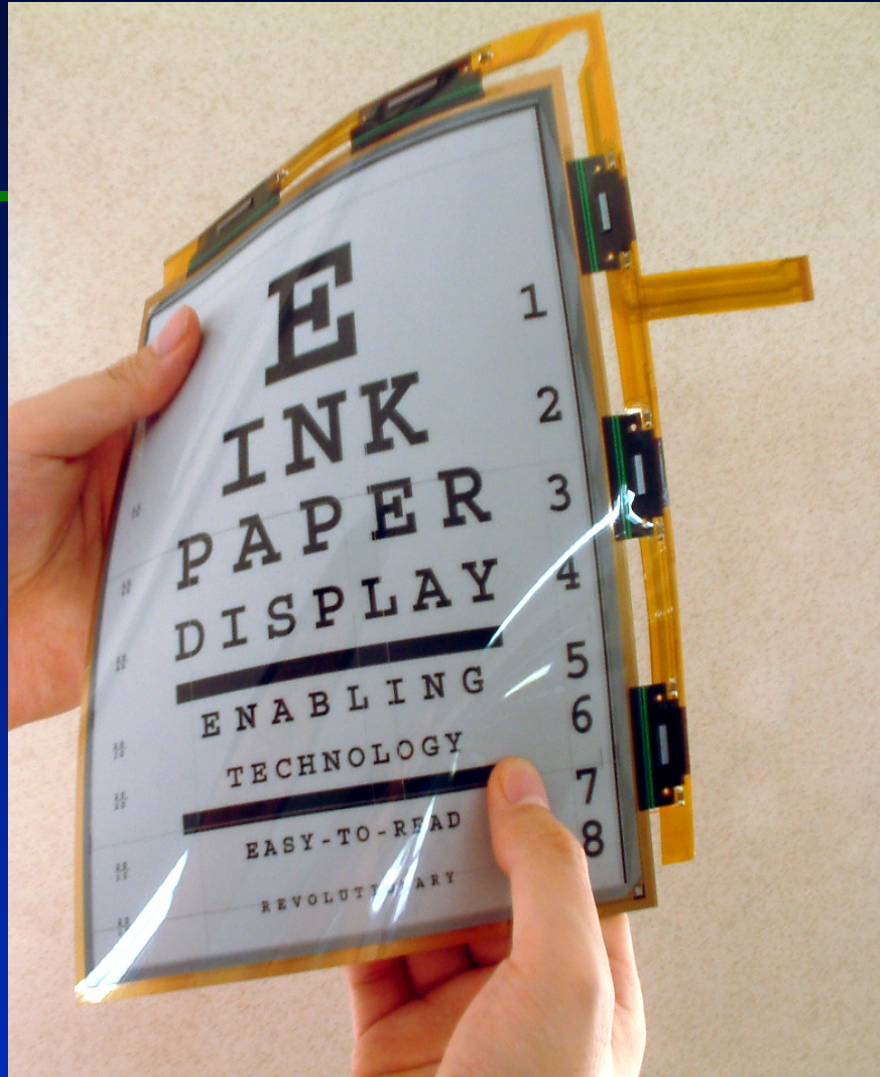

Flexible Tablet-Sized Display From L.G. Philips  
LCD and E Ink Corporation

# Kindle 2

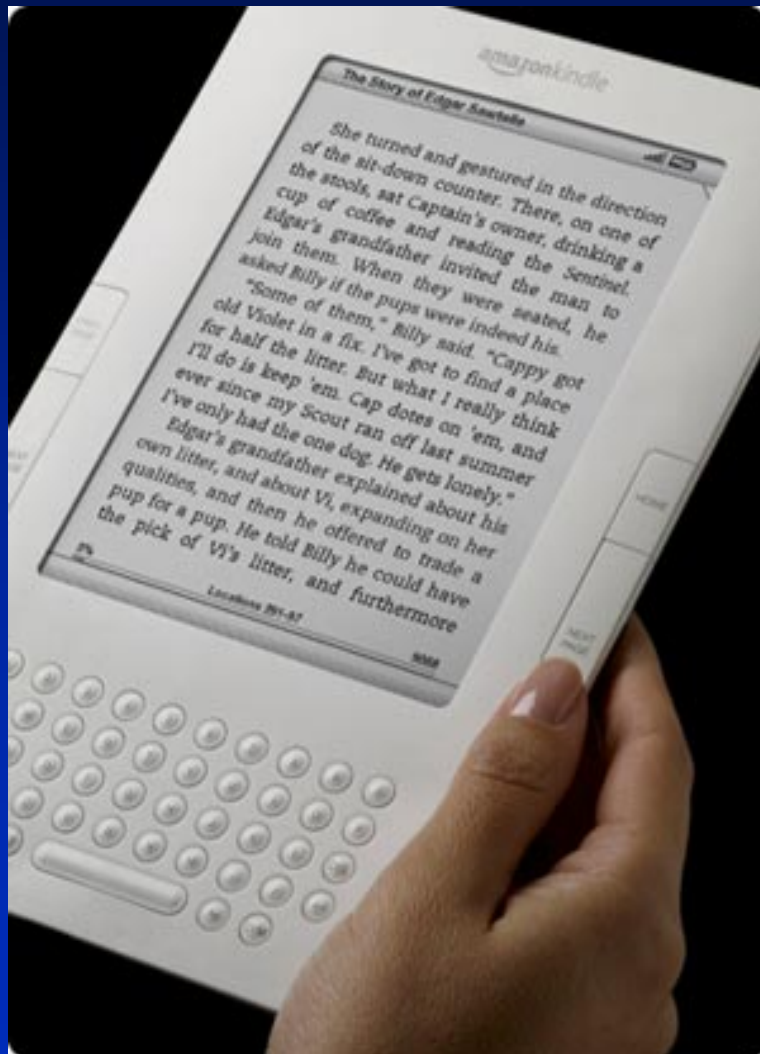

# Corning

---



# Corning Fusion Process

---

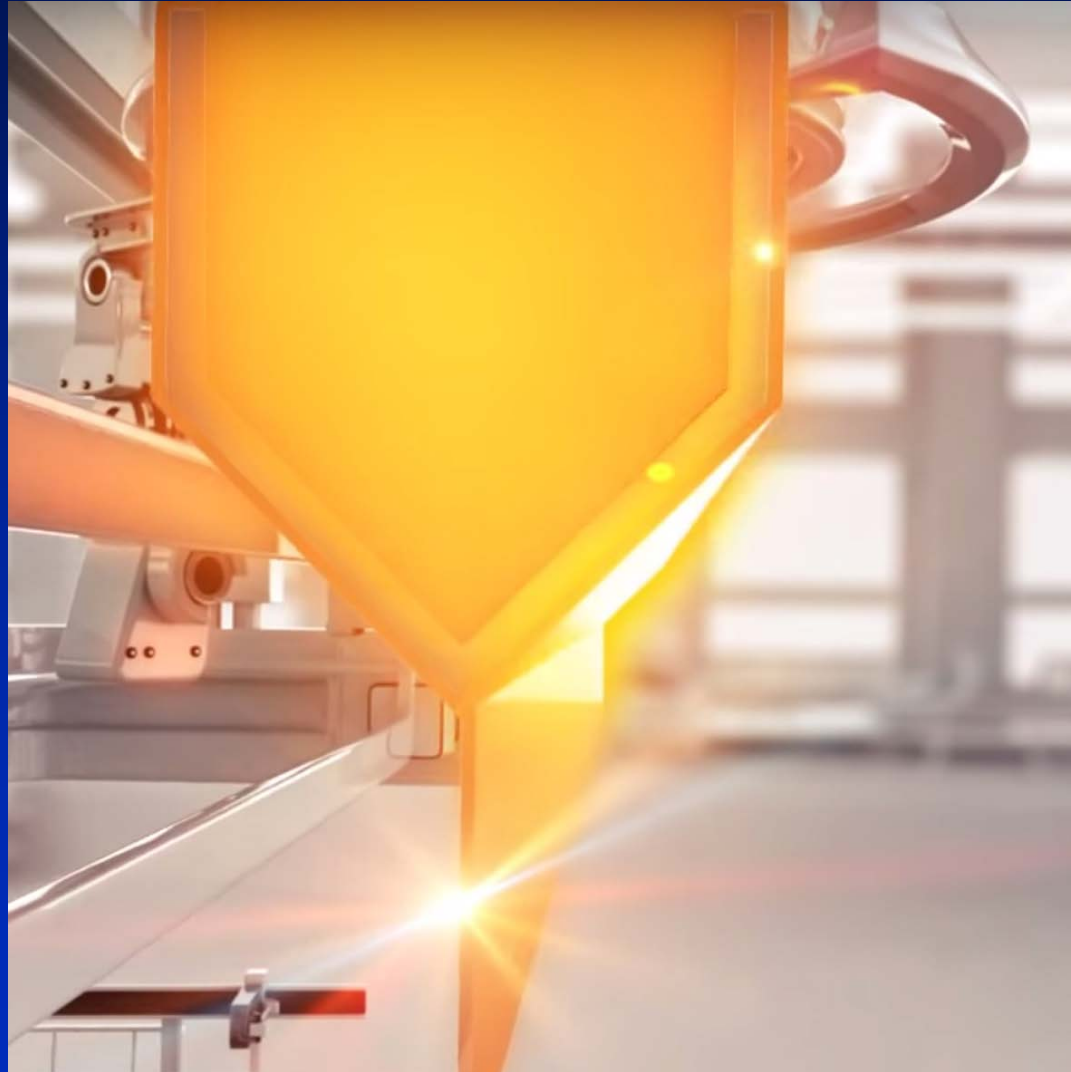

# Dell's UltraSharp Display

2017



\$3,699.99

7,680 x 4,320 resolution

# LG 88-inch 8K Display

2018



# Sony's 2098 ppi

9/29/2016

## Highest Resolution Mobile Displays PPI Smackdown!

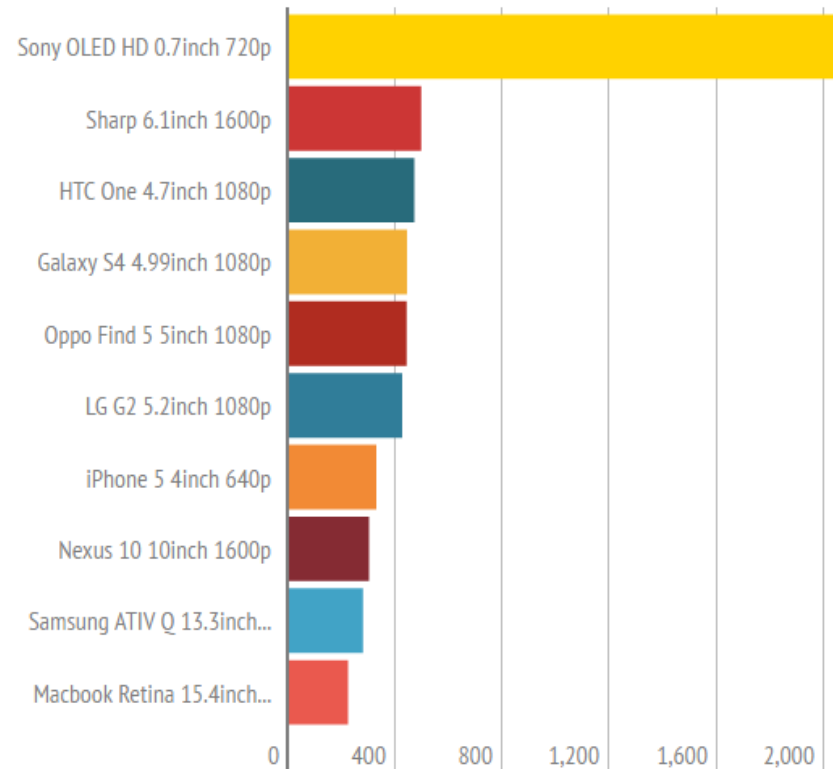

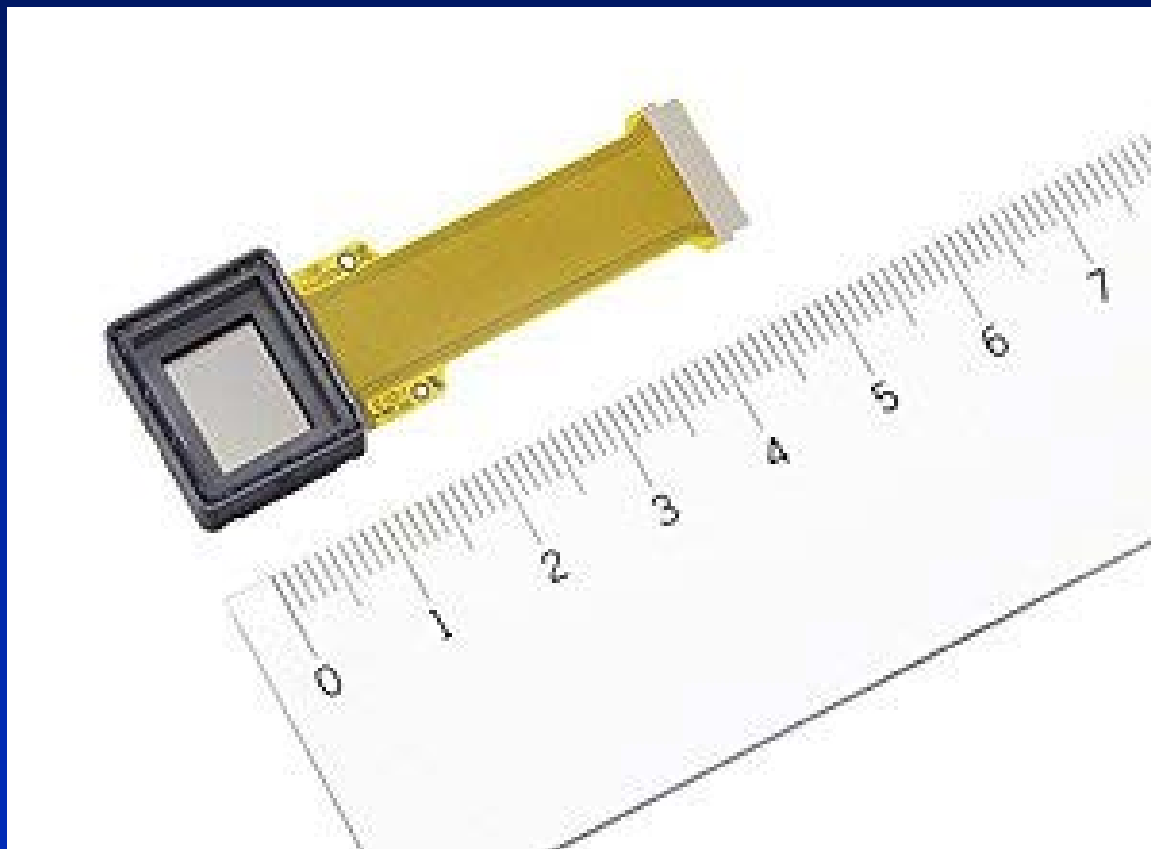



# Retinal Displays

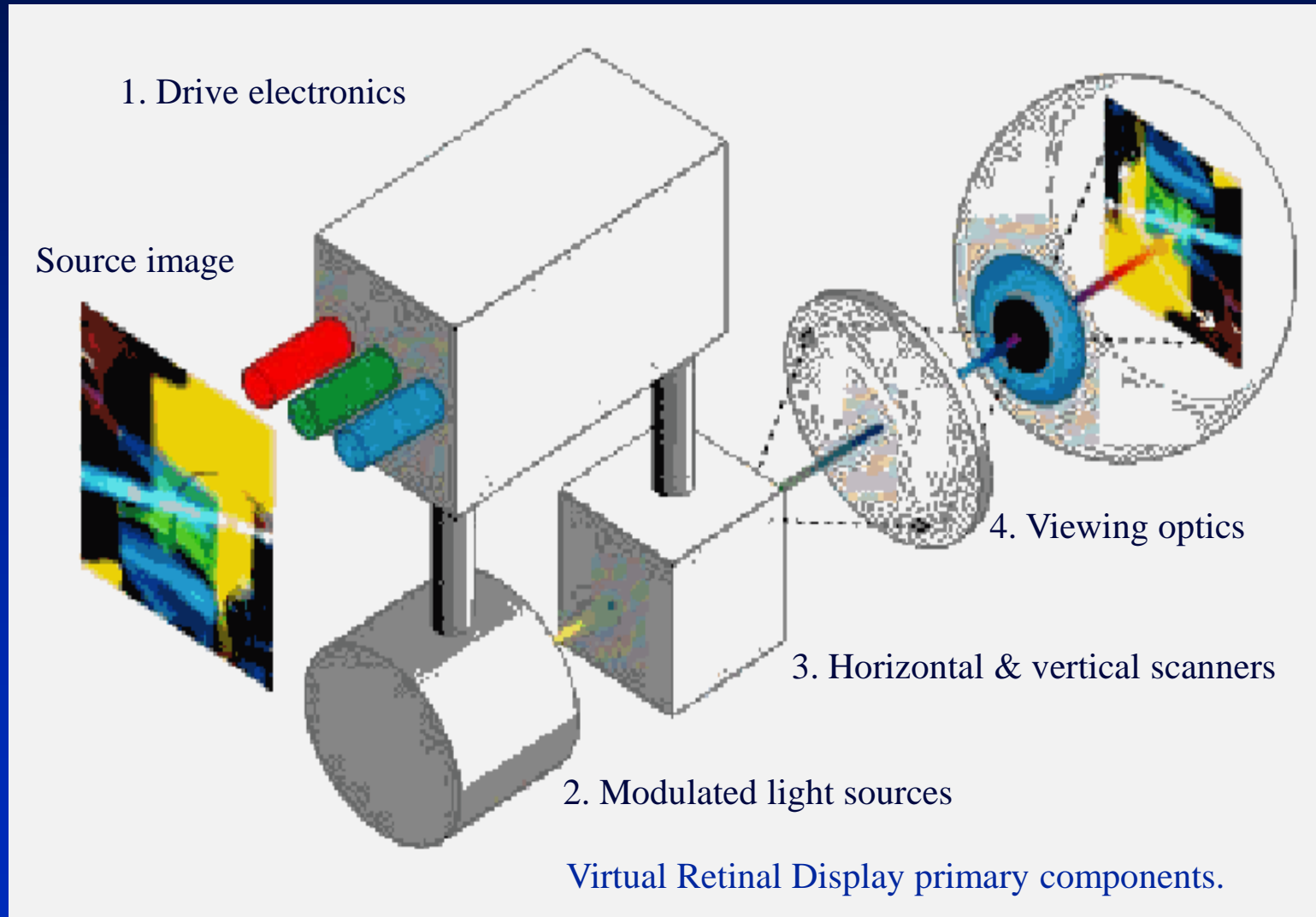

This schematic diagram illustrates the functional components of a laser-scanned display system.

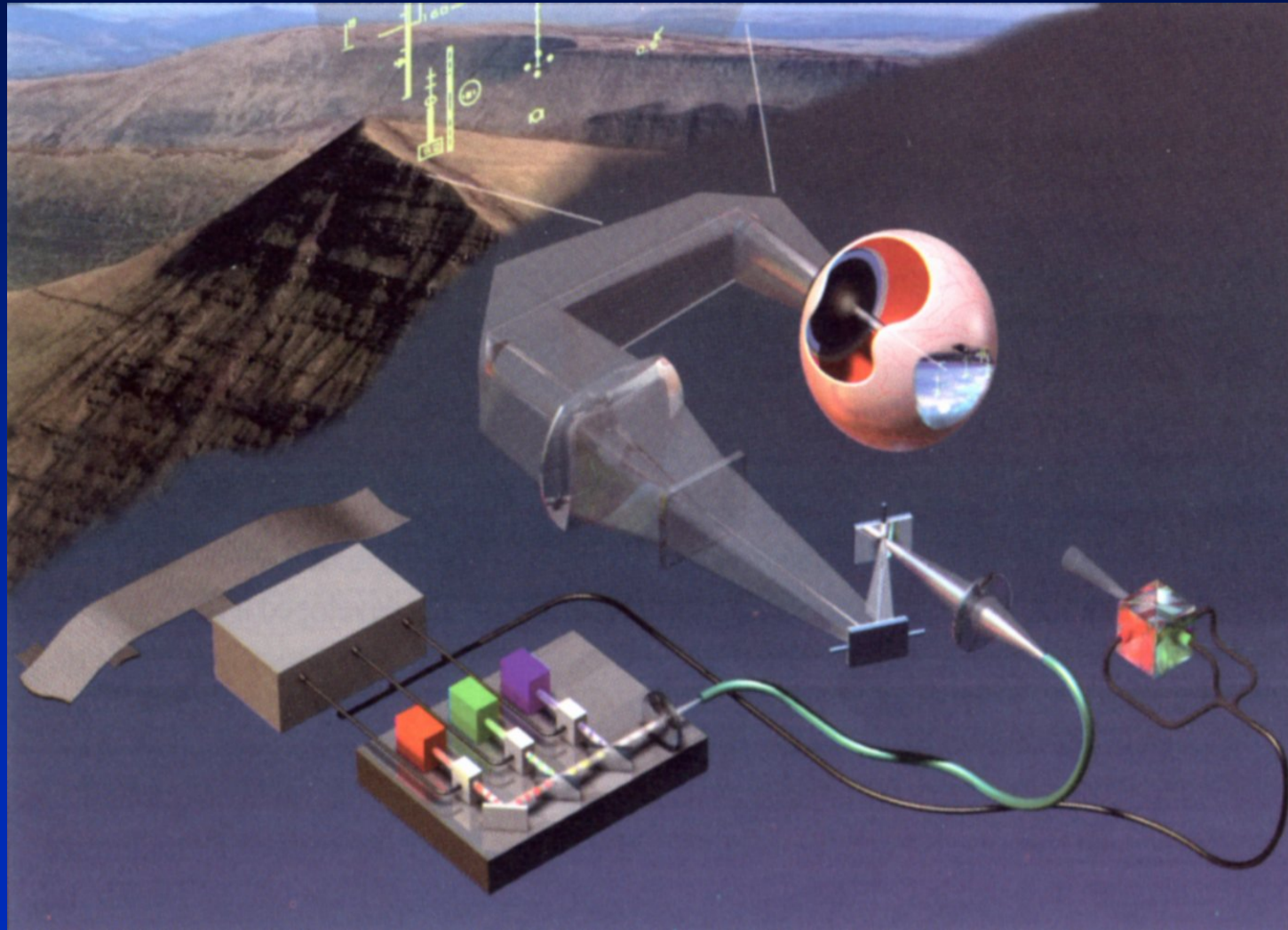

HMD information must have sufficient luminance to be seen when overlaid on realworld views.

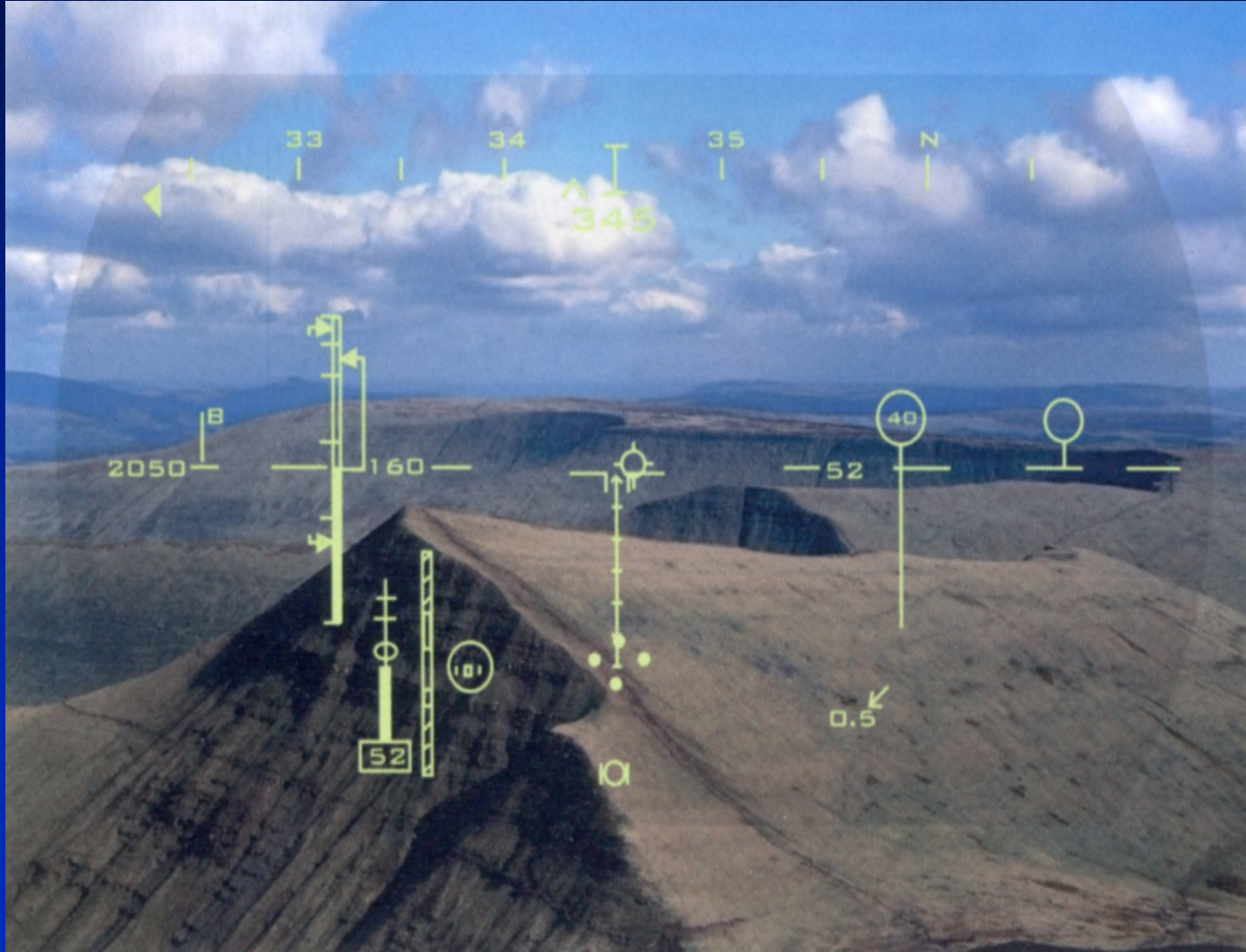

# Nomad for Commercial, Industrial and Automotive Applications

11. Install the ignition coil cover (A) and make sure the cover fits.

12. Clean nearby engine contact.

13. After installation, check that all tubes, hoses and connectors are installed correctly.

14. Refill the radiator with coolant.

6 x 10 mm  
12 N·m  
(1.2 kgf·m, 8.7 lbf·ft)

MEASURING DISC PARALLELISM

Orig. Th  
F.O.  
R.O.  
Min. Th  
F.O.  
R.O.  
Max. R  
0.0

MEASURING DISC PARALLELISM

Orig. Th  
F.O.  
R.O.  
Min. Th  
F.O.  
R.O.  
Max. R  
0.0

NOMAD FOR COMMERCIAL,  
INDUSTRIAL AND AUTOMOTIVE  
APPLICATIONS

MEASURING DISC PARALLELISM

Orig. Th  
F.O.  
R.O.  
Min. Th  
F.O.  
R.O.  
Max. R  
0.0

NOMAD FOR COMMERCIAL,  
INDUSTRIAL AND AUTOMOTIVE  
APPLICATIONS

# Smart Headlight

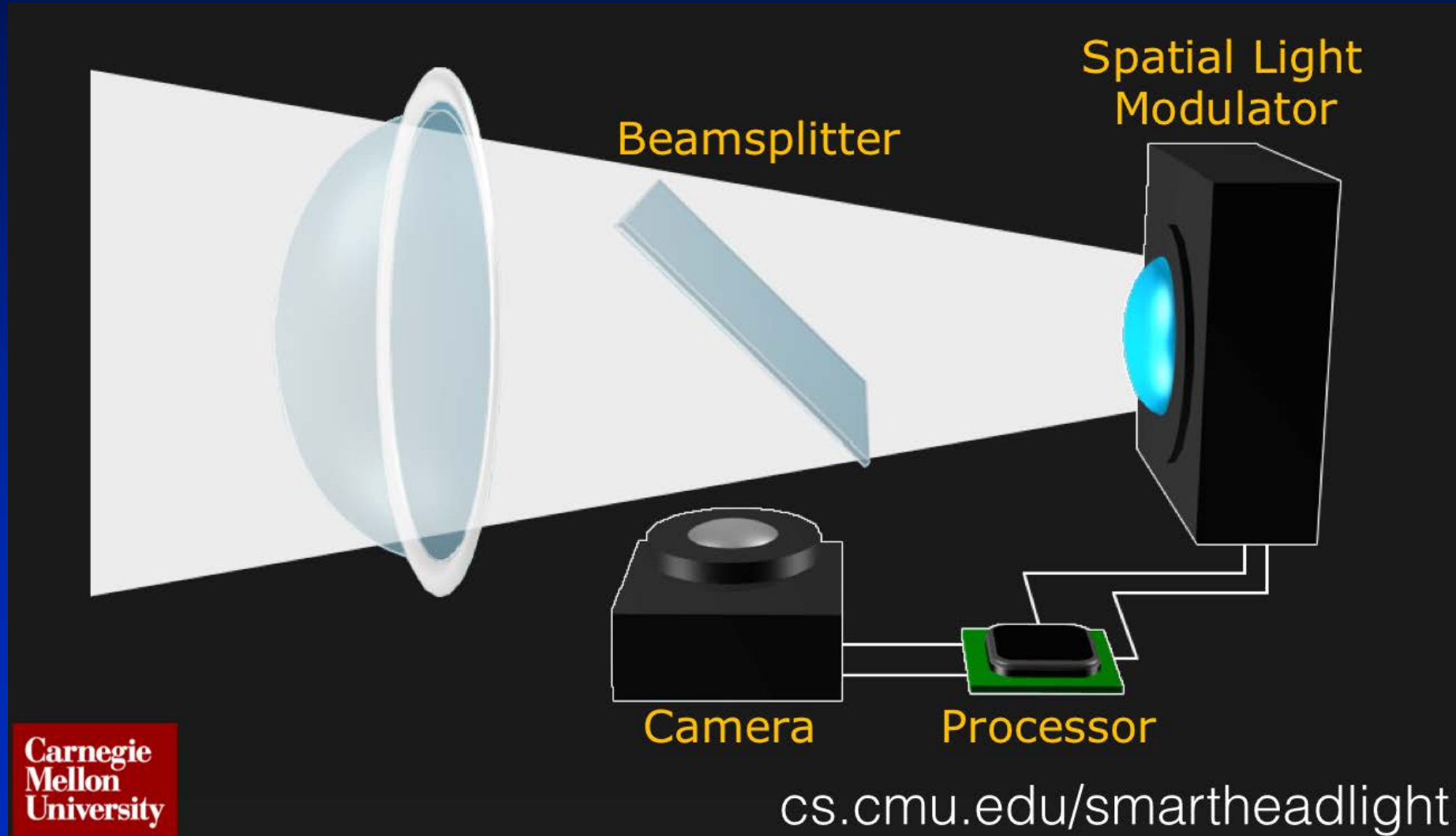

# Smart Headlights



**End**

---